

# INSTRUCTIO

# N

*WX,LX/UTC*

*MANUAL*

[www.kansai.org.ua](http://www.kansai.org.ua)

# **WX** *SERIES*

**Industrial Sewing Machines**

*WX8803/UTC*

*LX5801/UTC*

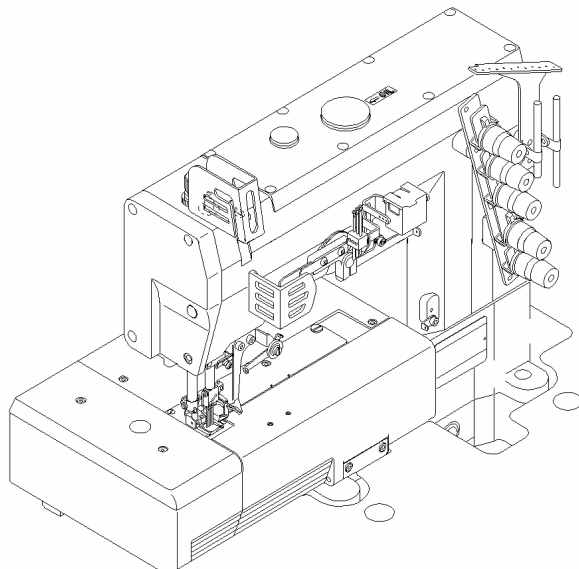

*First published : August 1997*  
*Fourth edition : August 2000*

**KANSAI**  
**SPECIAL®**

## **INTRODUCTION**

*Thank you for your purchasing Kansai Special's WX/UTC Series.*

*Read and study this instruction manual carefully before beginning any of the procedures and save it for later use.*

*This instruction manual describes adjustments and maintenance procedures for the thread trimmer.*

*Refer to the WX Series instruction manual for other information.*

# **CONTENTS**

1. HOW TO USE THE THREAD TRIMMER	1	10. ADJUSTING THE PRESSER FOOT LIFT	9
2. INSTALLING THE POSITION DETECTOR	1	11. ADJUSTING THE TOP COVER THREAD TRIMMER	
3. ADJUSTING THE THREAD TRIMMER AIR CYLINDER		11-1 Relationship between the position of the movable knife and the stable knife	10
3-1 Air cylinder stroke	2	11-2 Adjusting the top cover thread clamp spring	10
3-2 Air cylinder return spring	2	11-3 Adjusting the movable knife pressure spring	10
4. ADJUSTING THE THREAD TRIMMER SOLENOID		11-4 Adjusting the movable knife left to right	11
4-1 Solenoid stroke	2	11-5 Adjusting the movable knife front to back	11
4-2 Adjusting the solenoid return spring	2	11-6 Adjusting the height of the movable knife	11
5. ADJUSTING THE THREAD TRIMMER		11-7 Adjusting the solenoid return spring	12
5-1 Position of the movable knife and the stationary knife	3	11-8 Adjusting the top cover thread releaser hook	12
5-2 Adjusting the looper thread clamp spring	3	12. WIRING AND PIPING FOR PNEUMATIC DEVICES	13
5-3 Adjusting the movable knife pressure spring	3	13. WIRING AND PIPING FOR ELECTRIC DEVICES	13
5-4 Adjusting the movable knife holder left and right	4		
5-5 Adjusting the movable knife front to back	4		
5-6 Adjusting the movable knife up and down	5		
5-7 Relationship between the movable knife, needle thread and looper thread	5		
5-8 Looper thread clamp spring pressure	5		
6. ADJUSTING THE THREAD RELEASER			
6-1 Thread releaser block	6		
6-2 Thread releaser connection plate	6		
6-3 Thread releaser lever	6		
6-4 Looper thread take-up	7		
6-5 Thread releaser plate	7		
6-6 Thread releaser hook	7		
7. SAFETY DETECTOR	7		
8. ADJUSTING THE SPEED CONTROLLER AND AIR PRESSURE			
8-1 Adjusting the speed controller	8		
8-2 Air pressure	8		
9. ADJUSTING THE NEEDLE THREAD WIPER	8		

## 【1】 HOW TO USE THE THREAD TRIMMER

< Note >

*Do not use this thread trimmer with no fabric under the presser foot.*

- Pressing the pedal with toe (position A) starts the machine.

Releasing the pedal (position B) stops the needle at the top/bottom of its stroke (adjustable with the motor).

- If the needle stops at the bottom of its stroke as adjusted, pressing the pedal with heel (position C) raises the needle.

As soon as the needle stops at the top of its stroke by pressing the pedal with heel, the thread trimmer gets actuated (if the needle stops at the top of its stroke as adjusted, the thread trimmer gets actuated by pressing the pedal with heel).

- Returning the pedal to position B lowers the presser foot.
- The presser foot can be raised or lowered freely by releasing the pedal (position B) or pressing the pedal with heel (position C) until the pedal is placed at position A for the next sewing operation after the threads are cut.

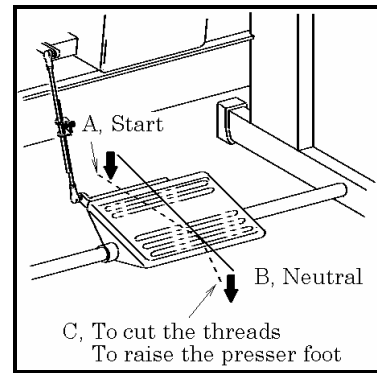

## 【2】 INSTALLING THE POSITION DETECTOR

- Install position detector A and tighten screw B temporarily.
- Fit positioner bar C onto the guide groove of the position detector. Then tighten screw D.
- Turn on the motor.

< Note >

*Remove the connector for the thread trimmer cylinder.  
Make sure the knife is retracted all the way.*

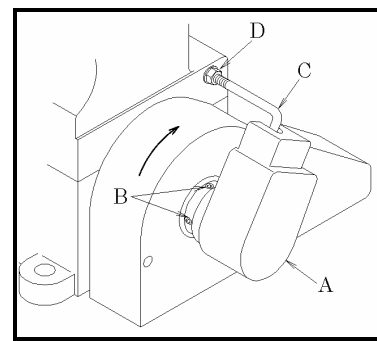

- Press the pedal with heel after two to three stitches are formed by pressing the pedal with toe. Then the needle stops.

- Loosen screws B for the position detector.

Turn the machine pulley while checking that the position of screws B is not shifted.

Align mark P on handwheel E with the alignment mark on the arm. Then the needle bar is at the top of its stroke.

Tighten screws B to secure the position detector.

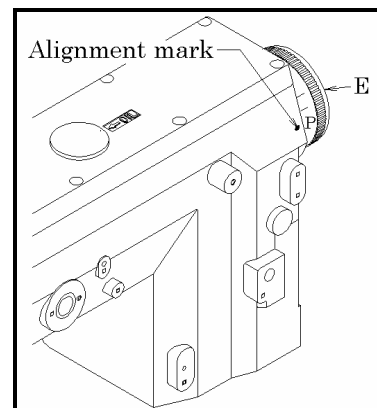

- Check to see if the needle bar stops at the top of its stroke by pressing and then releasing the pedal.

### 【3】 ADJUSTING THE THREAD TRIMMER AIR CYLINDER

#### 3-1 Air cylinder stroke

The stroke of the air cylinder should be approximately 15mm. Adjustment is made by loosening collar B and screw A. There should be a clearance of 15mm between rubber cushion F and the rear end of the cylinder.

Position joint shaft E so that the distance from left end of the cylinder mounting bracket D to the center of joint shaft E is approximately 55.3mm when the cylinder retracts.

Adjustment is made by loosening nut C.

In these conditions, there should be a clearance of approximately 19mm between thread releaser block H and cylinder mounting bracket D.

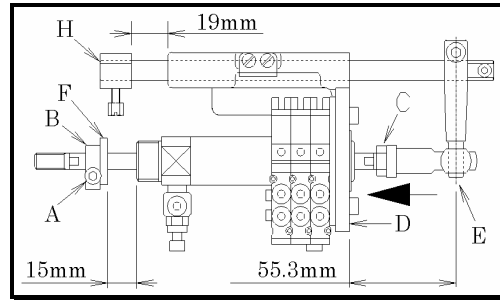

#### 3-2 Air cylinder return spring

There should be a clearance of approximately 28mm between ring G and air cylinder mounting bracket D when the plunger of the air cylinder protrudes.

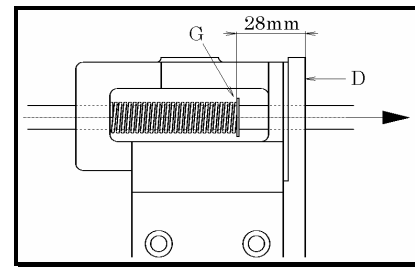

### 【4】 ADJUSTING THE THREAD TRIMMER SOLENOID

#### 4-1 Solenoid stroke

The stroke of the solenoid should be approximately 15mm. Adjustment is made by removing rubber cover F and loosening screw A. There should be a clearance of 15mm between rubber cushion B and the rear end of the solenoid. Position joint shaft E so that the distance from the left end of solenoid mounting bracket D to the center of joint shaft E is approximately 55.3mm when the solenoid has retracts. Adjustment is made by loosening nut C.

In these conditions, there should be a clearance of approximately 19mm between thread releaser block J and solenoid mounting bracket D.

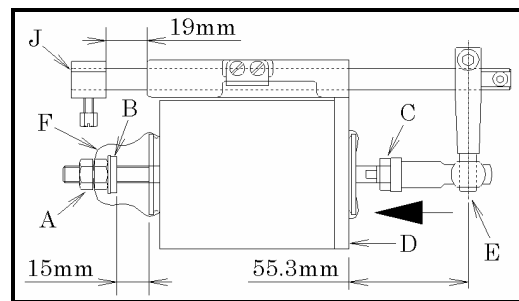

#### 4-2 Adjusting the solenoid return spring

There should be a clearance of 42mm between solenoid return spring collar H and solenoid mounting bracket D when the plunger of the solenoid protrudes. Adjustment is made by loosening screw G on solenoid return spring collar H.

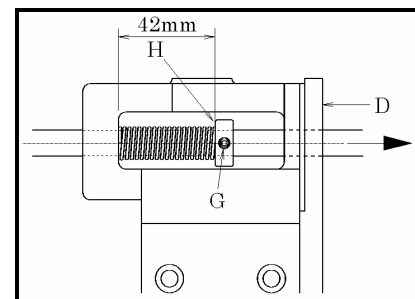

## 【5】 ADJUSTING THE THREAD TRIMMER

### 5-1 Position of the movable knife and the stationary knife

#### ■ Position of the movable knife

Set the (a 1) part of the movable knife A parallel to the (g 1) part of the stationary holder G.

Set the distance from point of movable knife A and the center of left screw H at approximately 73.5mm.

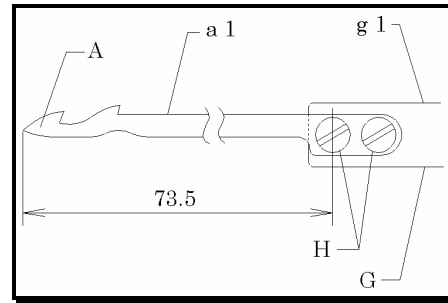

#### ■ Relation between the stationary knife and the movable knife.

Adjust the engagement between blade (a 3) for trimming looper thread and stationary knife to be 1mm when movable knife is at the extreme right.

So that between the point of blade (a 2) for cutting needle thread and corner (b 1) of stationary knife B to be 0.4mm. The adjustment is made by loosening screw C. Note that the looper thread clamp spring is simultaneously loosened.

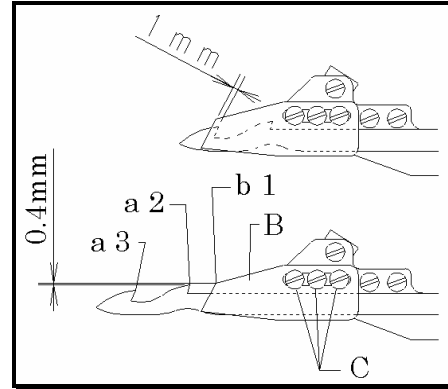

### 5-2 Adjusting the looper thread clamp spring

Position of looper thread clamp spring D so that the part (a 1) of movable knife and the part (d 1) of looper thread clamp spring are on the same plane.

And adjust it will protrude approximately 2.2mm from the point of movable knife A when movable knife is at the extreme right.

Adjustment is made by loosening screw C.

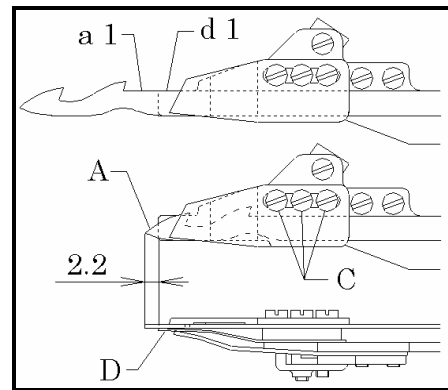

### 5-3 Adjusting the movable knife pressure spring

Position of movable knife pressure spring F so that the part (a 1) of movable knife parallel to the part (f 1) of movable knife pressure spring.

And adjust it will protrude approximately 4.8mm from the point of movable knife A when movable knife is at the extreme right.

Adjustment is made by loosening screw E.

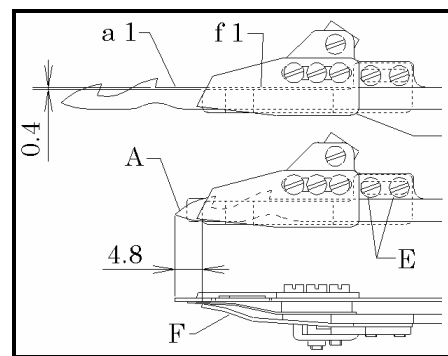

#### 5-4 Adjusting the movable knife holder left and right

With movable knife A at the extreme left end of its travel, there should be a distance of 23mm from the center of the needle bar to the point of movable knife A.

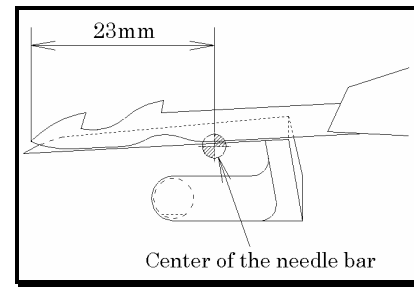

- When the movable knife is at the extreme right end of its travel, Align the part (a2) of movable knife (A) parallel with the part (r1) of knife holder plate (R).
- Easy test for checking the correct travel of the movable knife is to agree the mark (T) of driving lever (M) to the mark (t) of knife holder plate (R) at the extreme right end or left end of its travel. The left side is a standard position for the mark (N) of guide lever ring (R).

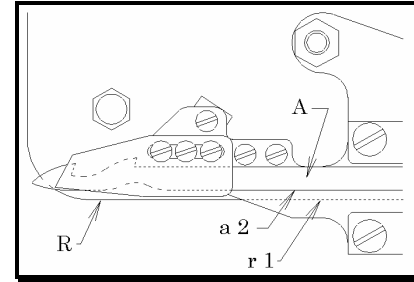

- Adjustment is made by loosening the screw (B) of connecting lever (E) and moving guide bar (D) on right and left. Use lever (M) for final slight adjustment. Normal setting aligns the right end (e) of connecting lever (E) level with the step position (d) of guide bar (D).

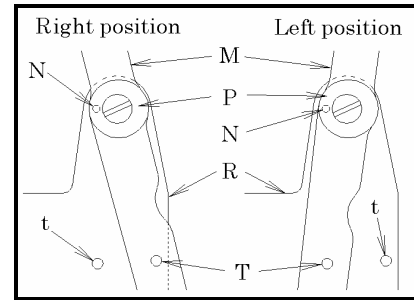
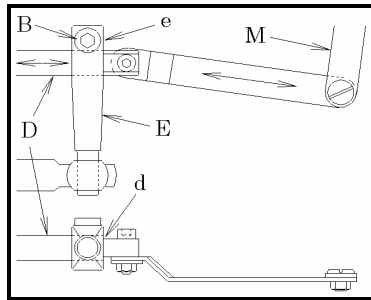

#### 5-5 Adjusting the movable knife front to back

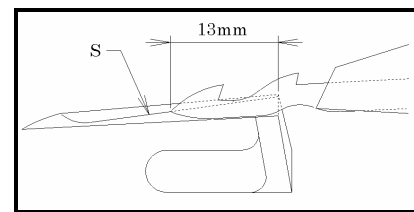

To adjust the movable knife front to back, alignment line (S) of movable knife over the looper with the point of movable knife 13mm moved to the left from the right end of looper. To adjust, when loosening screw U and turning lever ring P clockwise, the movable knife point moves forward and turning it counterclockwise, the point moves backward.

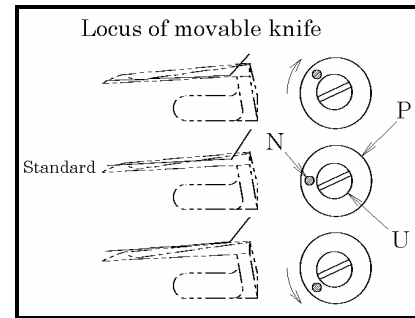

### 5-6 Adjusting the movable knife up and down

There should be a clearance of 0.2mm between movable knife and the top surface of looper.

The adjustment is made by loosening nut X and moving stationary knife holder (W).

After the above adjustment, make sure the movable and stationary knife holders move smoothly. Do not adjust this clearance by changing the height of the looper.

Otherwise it may cause skip stitching.

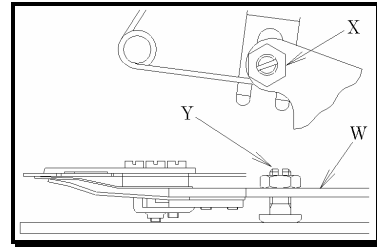
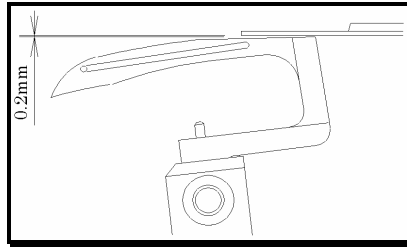

### 5-7 Relationship between the movable knife, needle thread and looper thread

After all the adjustments are made, check the following before threading to start the machine.

- Movable knife A should enter needle thread loops B. Cutting edge C for the looper thread should pass looper thread D.

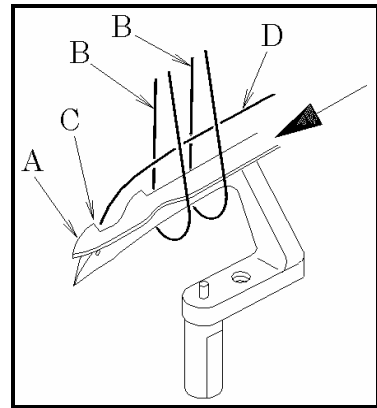

- When the movable knife is returning home, the needle threads and looper thread are pulled to the right by cutting edges E and F and cut by the stationary knife.

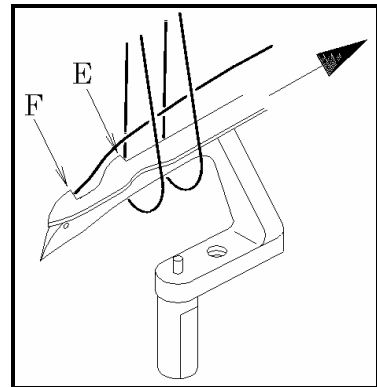

### 5-8 Looper thread clamp spring pressure

The looper thread clamp spring holds the looper thread after it is cut. To adjust the pressure of thread clamp spring H, turn adjusting screw G. To increase the pressure, turn it clockwise. To decrease the pressure, turn it counterclockwise. The machine is supplied with a spun thread (#60). The pressure of the thread clamp spring is factory-set at approximately 90g. Adjust the pressure for other threads.

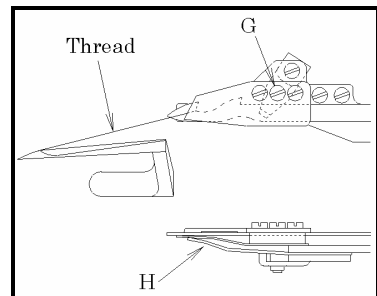



## 【6】 ADJUSTING THE THREAD RELEASER

### 6-1 Thread releaser block

With the thread trimmer air cylinder rod or the solenoid rod at the left end of its travel (the air cylinder is not operating), there should be a clearance of 4.0mm between the thread trimmer air cylinder bracket D and thread releaser block C. After this adjustment, tighten screw B.

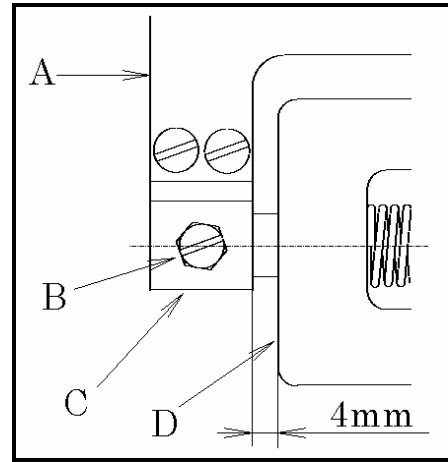

### 6-2 Thread releaser connection plate

Fit thread releaser connection plate A onto guide screw E with a clearance between A and thread releaser connection lever G.

Adjustment is made by loosening screw H.

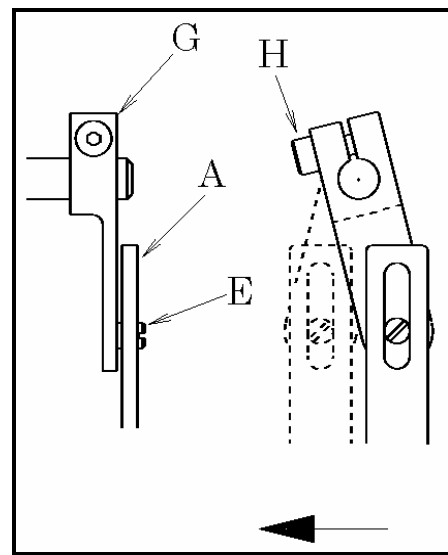

### 6-3 Thread releaser lever

When thread releaser block C operates, thread tension disk K should open as fast as possible. To make this adjustment, position thread releaser lever F and then tighten screw H on thread releaser connection lever G at the rear end of the arm.

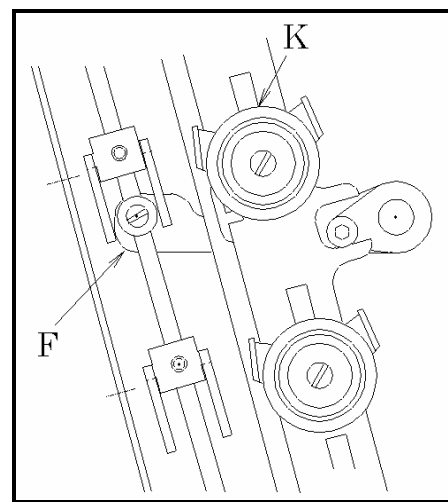

#### 6-4 Looper thread take-up

This machine is equipped with looper thread take-up L. Thread looper thread take-up L with a looper thread.

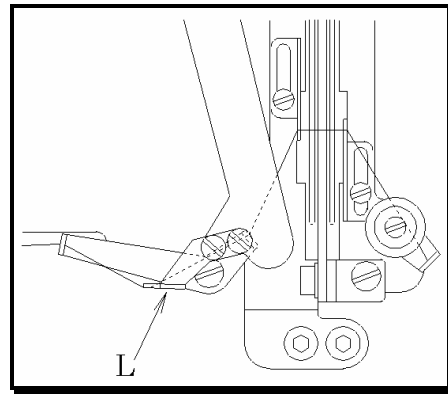

#### 6-5 Thread releaser plate

The thread tension disks should open as fast as possible. To make this adjustment, loosen screw B on thread releaser plate adjusting collar A and then adjust the position of thread releaser plate C. With the upper end of thread releaser bar D 39mm protruded from the top surface of thread releaser bar guide E, secure thread releaser bar D on thread releaser connection plate F with screw G. In the above condition, the length of spring H should be approximately 4mm.

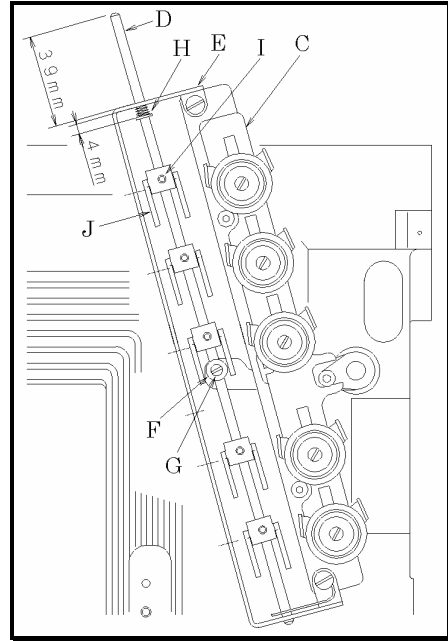

#### 6-6 Thread releaser hook

The needle thread should not be shown long on the back of the fabric. Adjustment is made by loosening screw I and positioning thread releaser hook J.

To decrease the amount of thread to be supplied, raise the thread releaser hook. To increase the amount of thread to be supplied, lower the thread releaser hook.

Do not decrease the amount too much. Otherwise stitches at the start of sewing will not be formed.

### **[7] SAFETY DETECTOR**

- The safety detector is included so that the machine will not run if the thread trimmer does not return home safely after the operation. Switch A on the safety detector must be ON (switch A is pressed) during sewing (the thread trimmer is completely at home). Adjustment is made by loosening screws B and E and moving brackets C and D as required.

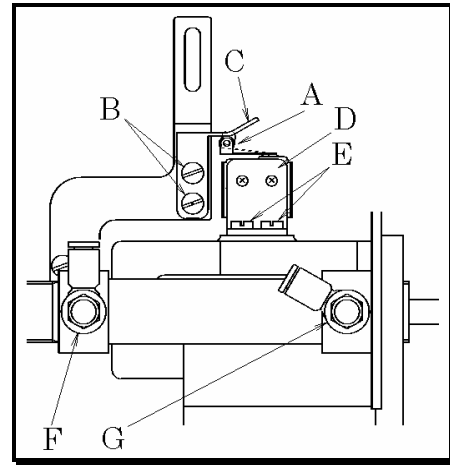

## 【8】 ADJUSTING THE SPEED CONTROLLER AND AIR PRESSURE

### 8-1 Adjusting the speed controller

Speed controller F controls the speed when the thread trimming knife holder projects.

Speed controller G controls the speed when the thread trimming knife holder retracts.

If the speed is too fast, the knife holder will be greatly shocked. This will cause trouble such as a thread is trimmed before it is caught in the knives or it is not clamped correctly by the thread clamp.

If screw F is too loosened, the holder will protrude too fast and then the position of the movable knife will become unstable, causing cutting error.

If screw G is too loosened, the holder will retract too fast and then a looper thread may not be held properly.

### 8-2 Air pressure

Set the regulator at 4~5kg/cm<sup>2</sup>.

An air pressure of more than 5.0kg will cause trouble.

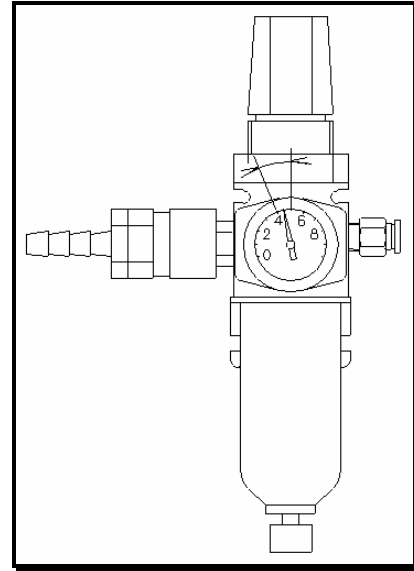

## 【9】 ADJUSTING THE NEEDLE THREAD WIPER

1. Tighten screw E to position lever B horizontally. There should be a 0 to 0.3mm clearance between bracket C and stopper ring D.
2. Secure shaft F with screw G. There should be 1mm clearance between lever B and secure shaft F.
3. Position thread wiper K with screw H. The distance between the left end of the thread wiper and the center of the needle bar should be approximately 19mm when the thread wiper is all the way to the left and clearance between the needle center and point P of the thread wiper should be approximately 1mm.
4. The distance between the left needle and thread wiper K should approximately 0.5mm with screw A.
5. Position thread wiper K parallel with flat spring M with screw L.

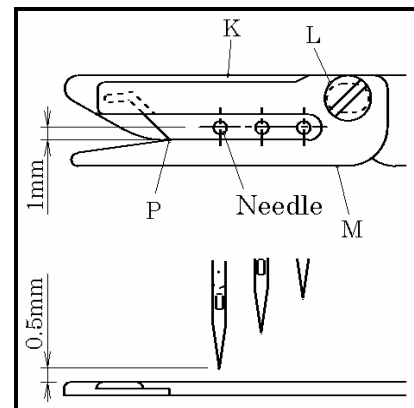
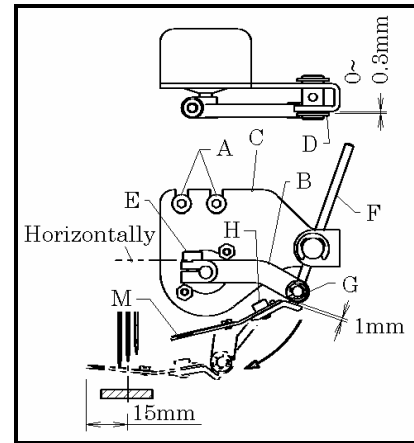



## 【10】 ADJUSTING THE PRESSER FOOT LIFT

- Foot lift on the machine with spreader  
6mm above the top surface of the needle plate
- Foot lift on the machine without spreader  
7mm above the top surface of the needle plate

To make the above adjustment, loosen screw D on crank lever C and set the clearance between slot A on the presser bar clamp connection plate and screw B at 0.5~1mm.

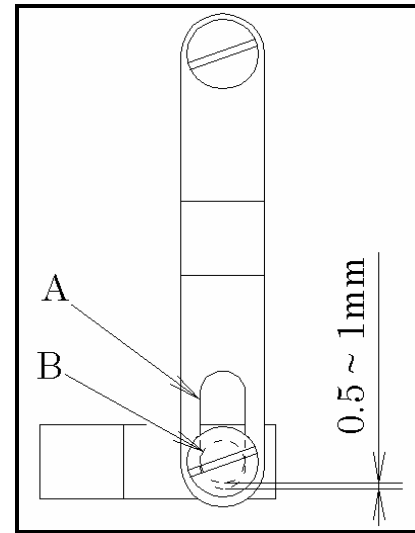
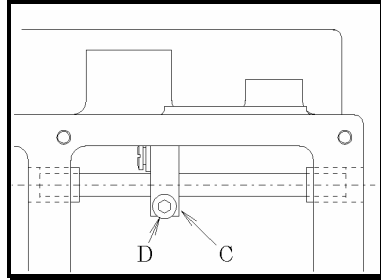

- Pneumatic presser foot lift  
When the cylinder gets actuated, the presser foot should be 6mm or 7mm above the top surface of the needle plate. Position stopper E so that lever G cannot be lowered below stopper E. Then secure stopper E with nut F.

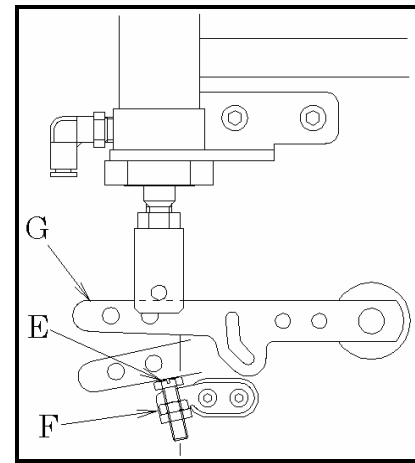

- Electric presser foot lift  
When plunger H moves in the direction of J, the presser foot should be 6mm or 7mm above the top surface of the needle plate. Adjust by using chain I. Position stopper E so that lever G cannot be lowered below stopper E. Then secure stopper E with nut F. Note that there is a little slack on chain I when plunger H moves in the direction of K.

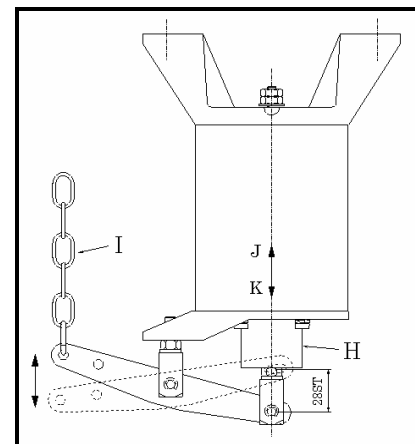



## 【11】 ADJUSTING THE TOP COVER THREAD TRIMMER

### 11-1 Relationship between the position of the movable knife and the stable knife

When the movable knife fully retracts, align hook point E of the movable knife with point F of the stationary knife. To make this adjustment, loosen screws A for stoppers B on pneumatic/electric top cover thread trimmer.

On the pneumatic/electric top cover thread trimmer, screws A should be centered in the slots of stoppers B. There should be a clearance of approximately 14mm between cylinder connection block D and end C of the cylinder. Make a fine height adjustment on the movable knife by referring to 11-6.

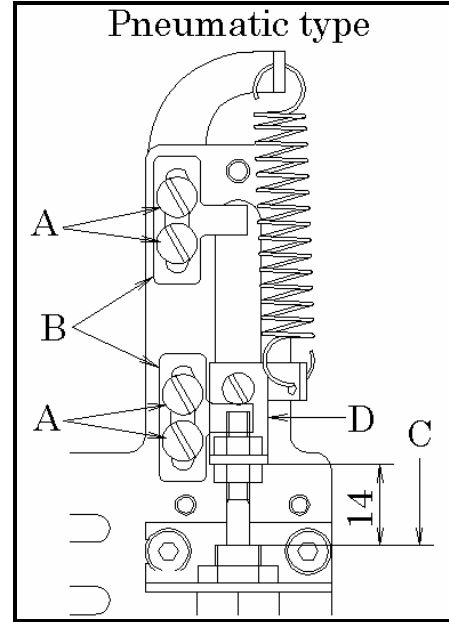
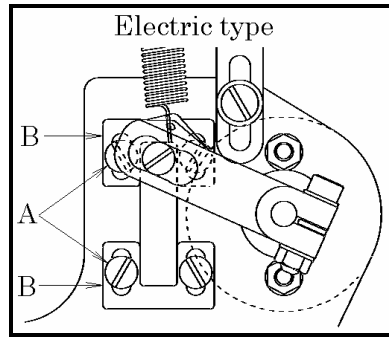

### 11-2 Adjusting the top cover thread clamp spring

Top cover thread clamp spring G should protrude approximately 3mm from end F of the stationary knife. Loosen screws I and adjust spring G so that it is parallel with the stationary knife.

The top cover thread is clamped and held by spring G after it is cut. To adjust the pressure of the spring, turn adjusting screw J. To increase the pressure, turn it clockwise. To decrease the pressure, turn it counterclockwise.

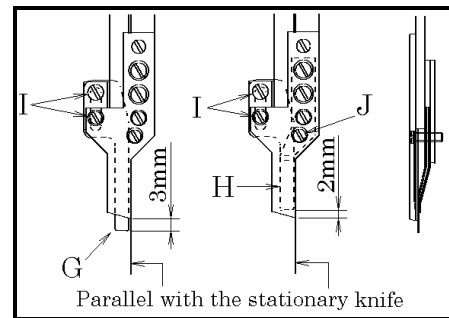

### 11-3 Adjusting the movable knife pressure spring

Movable knife pressure spring H should retract approximately 2mm from end F of the stationary knife. Loosen screws I and adjust spring H so that it is parallel with the stationary knife.

< Note >

*Excessive pressure causes needle breakage.*

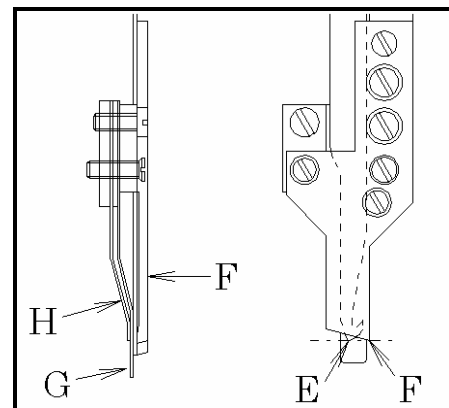

< Note >

The following adjustments should be made manually with the fabric under the presser foot when the needle is at the top of its stroke.

#### 11-4 Adjusting the movable knife left to right

Movable knife C should pass clearance B between spreader A and the left needle. Loosen screws H on bracket G. Adjust movable knife C while checking it does not touch spreader A or the left needle.

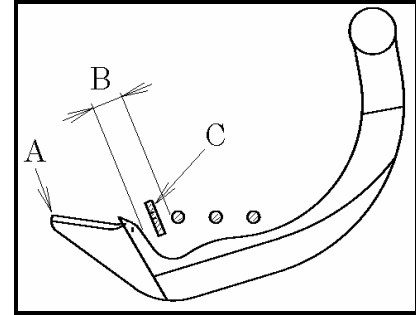

#### 11-5 Adjusting the movable knife front to back

The movable knife should hook the top cover thread when the movable knife returns home.

There should be a clearance of approximately 1mm between hook point D of movable knife C and the top cover thread. Adjustment is made by loosening screws J on movable knife mounting base I.

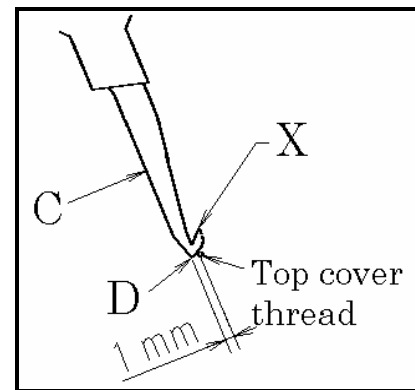

#### 11-6 Adjusting the height of the movable knife

When the movable knife is at the bottom of its travel, hook point X of the movable knife should be aligned with the top surface of the spreader.

Adjustment is made by moving stopper B (see the illustration on the previous page).

Then tighten screws F when bracket E is in the lowest position.

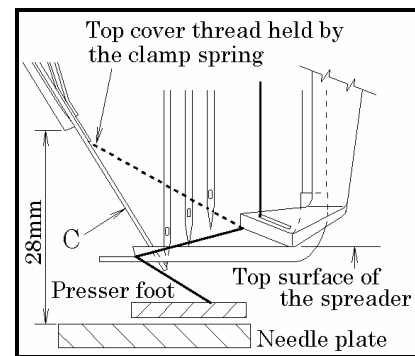

< Note >

Turn off the power first and then adjust by hand with the fabric under the presser foot.

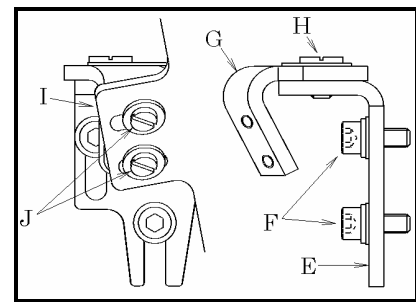

### 11-7 Adjusting the solenoid return spring

Available for the electric top cover thread trimmer.

Position spring bracket D so that screw E will be centered in the slot of spring bracket D. Set the clearance between the end of drive lever B and the step of solenoid shaft A at approximately 2mm. Then tighten screw C for drive lever B.

To adjust the returning pressure of the movable knife, loosen screw E for spring bracket D and move spring bracket D up or down. To increase the pressure, move up bracket D. To decrease the pressure, move down bracket D.

The pressure of spring F should be as light as possible, yet be sufficient to return the movable knife home correctly when the solenoid gets actuated.

< Note >

To prevent the top cover thread trimmer from vibrating, fit the end of screw H onto the plate and then tighten nut I.

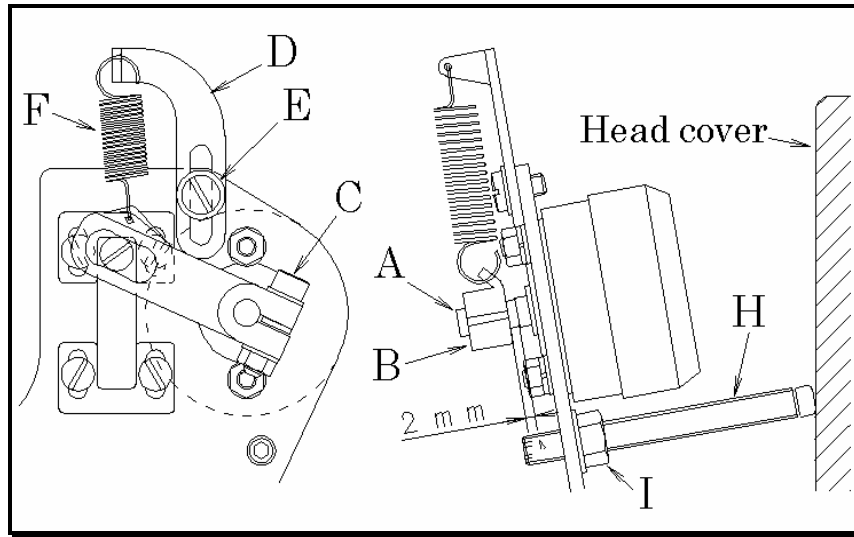

### 11-8 Adjusting the top cover thread releaser hook

To decrease the amount of the thread to be supplied, move up thread releaser hook G.

To increase the amount of the thread to be supplied, move down thread releaser hook G.

If the amount is too small, the top cover thread cannot be held after it is cut.

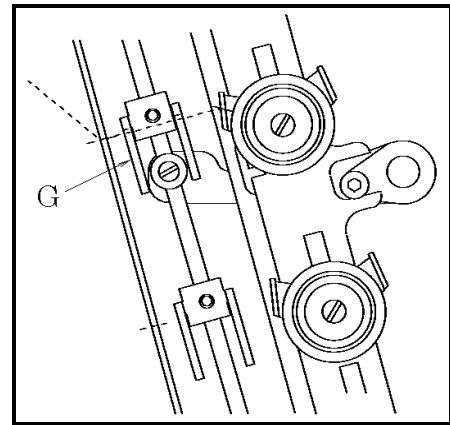

## 【12】 WIRING AND PIPING FOR PNEUMATIC DEVICES

- Connect air lines and cords by referring to the illustration below and the parts list.

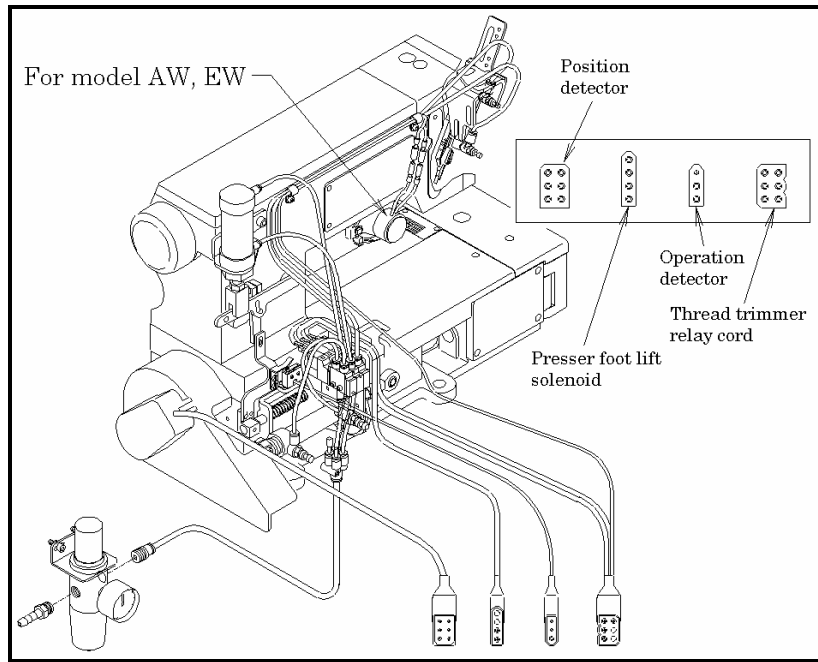

## 【13】 WIRING AND PIPING FOR ELECTRIC DEVICES

- Connect air lines and cords by referring to the illustration below and the parts list.

