

INSTRUCTION

www.kansai.org.ua

VW SERIES

Industrial Sewing Machines

V7100/D, DE, F, ML

W8100/D, DE, F, C

W8042

W8042-1

V7002-1S

W8103-1S

Second edition : March 1997

No. 970026

KANSAI
SPECIAL®

INTRODUCTION

Thank you for your purchasing Kansai Special's VFW Series.

Read and study this instruction manual carefully before beginning any of the procedures and save it for later use.

1. This instruction manual describes adjustments and maintenance procedures on this machine.
2. Before starting the machine, check to make sure the pulley cover, safety cover, etc. are secured.
3. Before adjusting, cleaning, threading the machine or replacing the needle, be sure to turn off the power.
4. Never start the machine with no oil in the reservoir.
5. Refer to the parts list as well as this instruction manual before performing preventive maintenance.
6. The contents described in this instruction manual are subject to change without notice.

CONTENTS

1. NEEDLES & THREADING THE MACHINE	
1-1 Needles	1
1-2 Replacing the needle	1
1-3 Threading the machine	1
2. MACHINE SPEED	
2-1 Machine speed & direction in which the machine pulley runs	3
2-2 Motor & belt	3
3. LUBRICATION	
3-1 Oil	4
3-2 Oiling	4
3-3 Replacing the oil and the filter element	4
4. SEWING MACHINE INSTALLATION	
4-1 Cutting the machine table	5
4-2 Installing the machine	6
5. TIMING OF THE LOOPER TO THE NEEDLES	
5-1 Angle and height for installing the looper	6
5-2 Looper left-to-right movement	7
5-3 Needle height	7
5-4 Length of the looper connecting bar	7
5-5 Looper setting distance	8
5-6 Needle/looper front-to-back relationship	8
6. FRONT AND REAR NEEDLE GUARDS	
6-1 Position of the needle guard (rear)	9
6-2 Position of the needle guard (front)	9
7. ADJUSTING THE FEED DOGS & STITCH LENGTH	
7-1 Feed dog height	10
7-2 Stitch length	10
7-3 Differential feed ratio	10
8. ADJUSTING THE SPREADER	
8-1 Position of the spreader	11
8-2 Position of the spreader thread eyelet	11
9. ADJUSTING THE PRESSER FOOT	
9-1 Presser foot pressure	12
9-2 Position of the presser foot & foot lift	12
10. ADJUSTING THE STITCH FORMATION	
10-1 Position of the needle thread eyelet	13
10-2 Position of the thread support	13
10-3 Position of the spreader thread eyelet	13
10-4 Position of the thread eyelet of the looper thread take-up	14
10-5 Position of the looper thread take-up	14
11. CLEANING THE MACHINE	14

1 NEEDLES & THREADING THE MACHINE

1-1 Needles

UY128GAS of Schmetz or Organ

Select **Threading diagram for W8042, W8042-1** read.

< Needles and needle size >

Schmetz UY128G	A, B, C ... Needle threads	m80	Nm90
	D..... Top cover thread		
Organ UY128GA	E, F, G... Looper thread	2	#14

< Right needle of model -1S series >

Schmetz TV7	Nm75
Organ TV7	#11

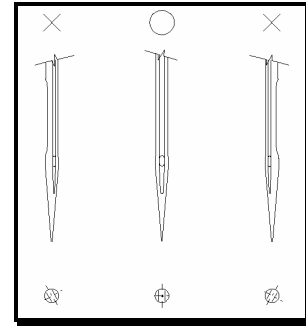

1-2 Replacing the needle

When replace the needle, check the needle carefully to see that the scarf is turned to the rear of the machine (see the illustration). Then install the needle correctly.

< Note >

Before replacing the needle, be sure to turn off the machine. A clutch motor continues running for a while after the machine is turned off. Therefore keep on pressing the pedal until the machine stops.

1-3 Threading the machine

Thread the machine correctly by referring to the illustration below.

Threading the machine incorrectly may cause skip stitching, thread breakage and/or uneven stitch formation.

Threading diagram for V7100, W8100/D, DE, F, C.

A B C Needle threads

Threading diagram for V7002-1S, W8103-1S

A, B, C, D ... Needle threads
E..... Top cover thread

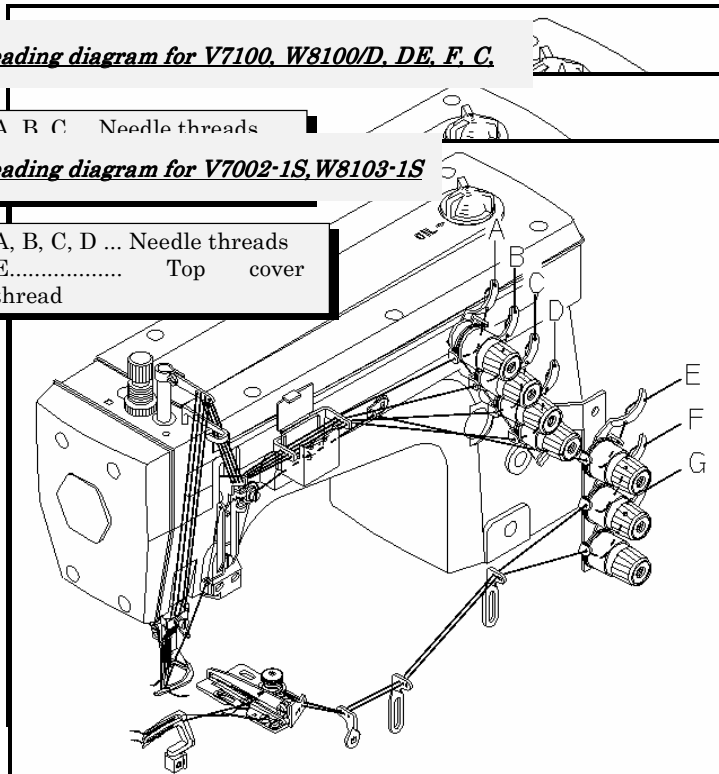

2 MACHINE

SPEED

2-1 Machine speed & direction in which the machine pulley runs

Refer to the table below for maximum and standard speeds of the Series. To extend machine life, run the machine approximately 15 - 20% below the maximum speed for the first 200 hours of operation (approx. 1 month). Then run the machine at the standard speed. The machine pulley turns counterclockwise as seen from the end of the machine pulley.

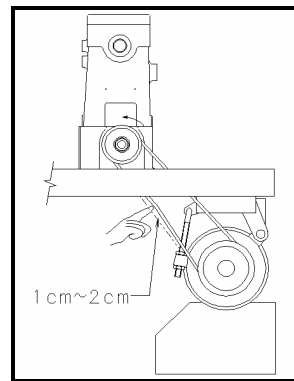

2-2 Motor & belt

Motor : 3-phase, 2-pole, 400W clutch motor

Belt : M type V belt

Select the proper motor pulley according to the machine speed (refer to the motor pulley outer diameter on the table below).

Adjust where to position the motor by pressing the finger onto the middle of the belt so that 1 - 2cm deflection can be obtained (see the illustration on the right).

< Machine speed >

TYPE	MAXIMUM SPEED	STANDARD SPEED
V7100	6000SPM	5500SPM
W8100	5500SPM	5000SPM
W8042-1	4500SPM	4000SPM
W8103-1S	3000SPM	2500SPM

< Motor pulley selection table >

Motor pulley outer diameter (mm)	Machine speed (SPM)	
	50Hz	60Hz
60	2500	2950
70	2900	3450
80	3300	3900
90	3700	4400
100	4100	4900
110	4500	5400
120	5000	5900
130	5300	(6400)
140	5800	(6900)

□3□LUBRICATION

3-1 Oil

Use Kansai Special's genuine oil.
(Part No. 28-611 : 700cc)

3-2 Oiling

- To fill the machine with oil

Remove rubber plug A from the oil hole. Fill the machine with oil until the oil level is at the top line (see H in the illustration) on oil gauge C. After the first lubrication, add oil so that the oil level will be between H and L.

- To check for proper oil flow

After filling the machine with oil, run the machine to check the oil is splashing from oil pipe outlet B.

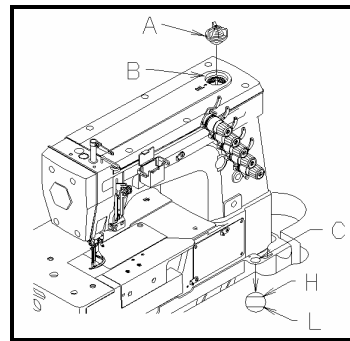

3-3 Replacing the oil and the filter element

To extend machine life, be sure to replace the oil after the first 250 hours of operation.

To replace the oil, follow the procedures below.

1. Remove the V belt from the motor pulley and then remove the machine from the table.
2. Remove screw D and then drain the oil.
Be careful not to stain V belt with the oil.
3. After draining the oil, be sure to tighten screw D.
4. Fill the machine with oil by referring to 3-2 shown above.

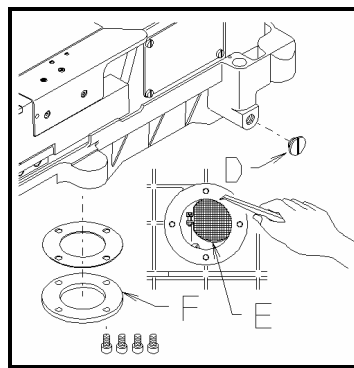

If filter element E is contaminated, proper oiling may not be performed. Clean the filter element every six months. If just a little or no oil flows out from the nozzle with the proper amount of oil in the machine, check the filter element. To clean the filter element, remove oil filter cap F.

4 SEWING MACHINE INSTALLATION

4-1 Cutting the machine table

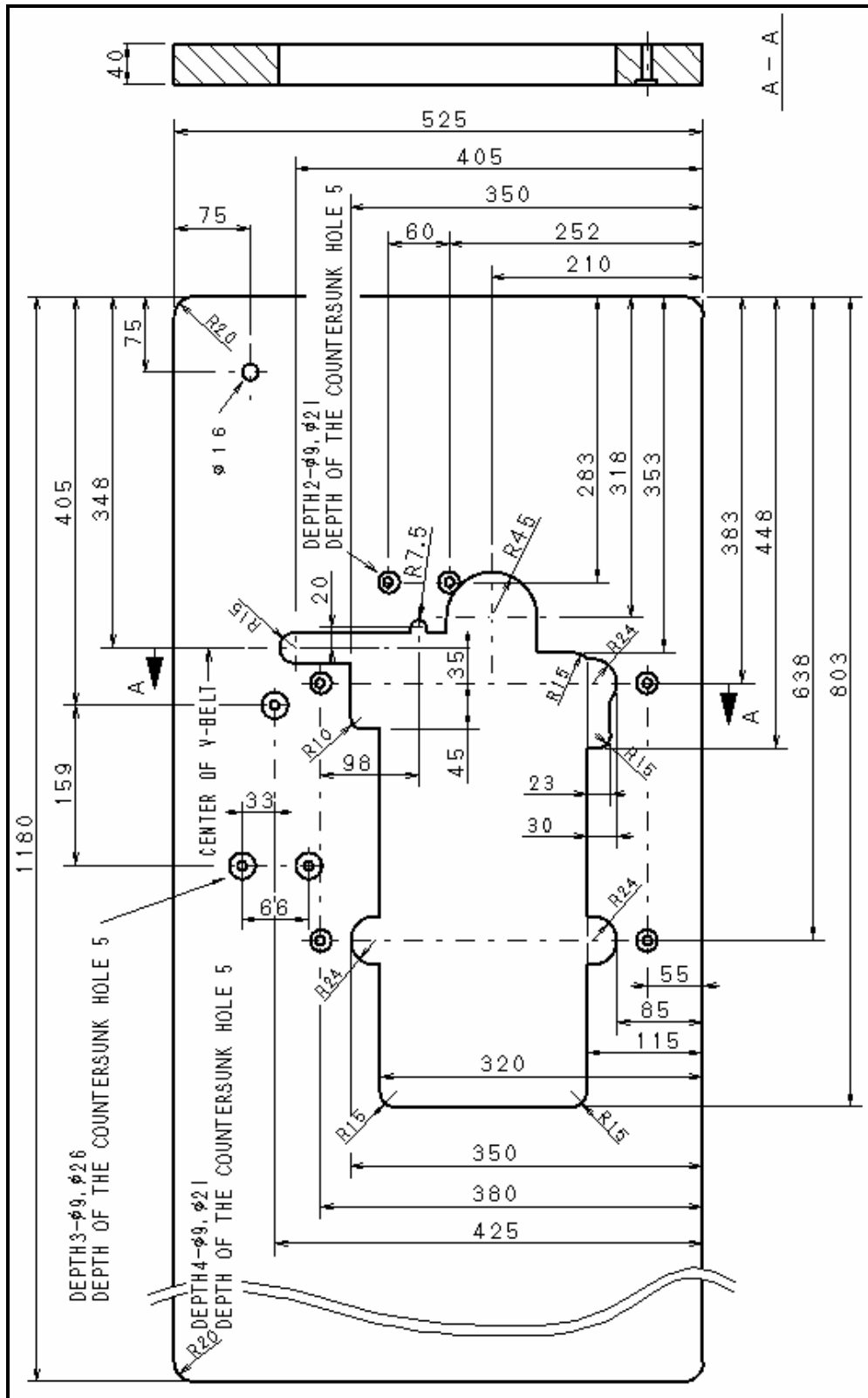

4-2 Installing the machine

Install the brackets on the underside of the table board (see the illustration below).

Fit the rubber cushions onto the brackets.

Mount the machine head on the rubber cushions.

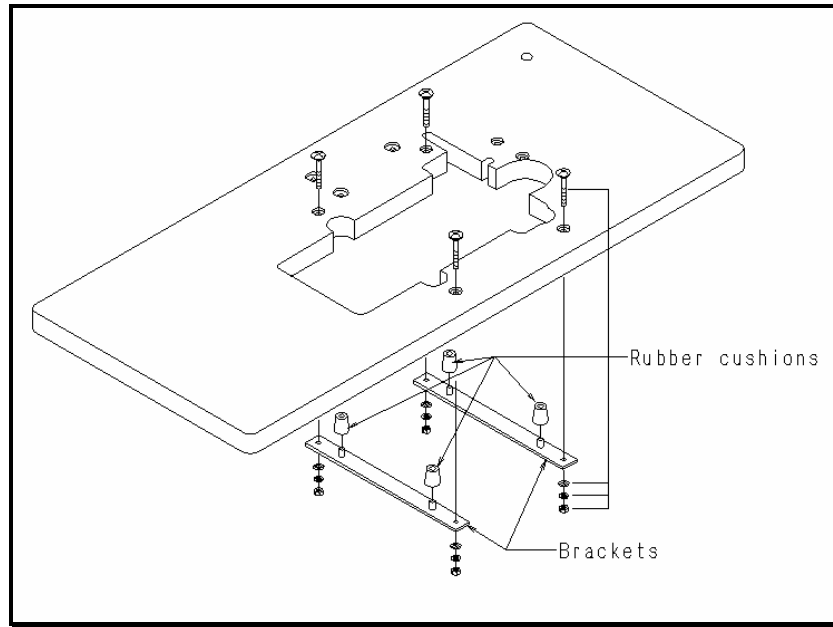

5 TIMING OF THE LOOPER TO THE NEEDLES

5-1 Angle and height for installing the looper

To obtain the proper angle and height, insert the looper fully into looper holder A and then tighten screw B. The proper angle for the looper on V7100 and W8100 is 3° . Distance at 25mm from the point of the looper between the bottom of the looper blade and the extension line from the point of the looper: Approximately 1.3mm

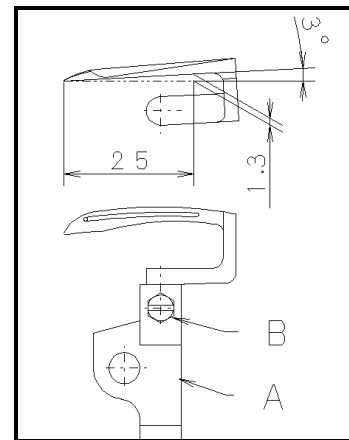

5-2 Looper left-to-right movement

When the point of the looper, moving to the left or right, has reached the left side of the left needle, distances As from the top of the left needle's eye to the point of the looper should be the same. (see the illustration on the right).

To adjust the timing of the looper to the needles, remove the machine cover, loosen three screws C on eccentric B and then shift the eccentric by turning the machine pulley while holding the eccentric.

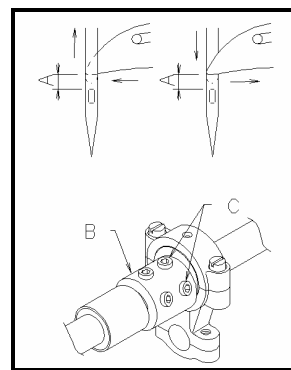

5-3 Needle height

When the needle bar is at the top of its stroke, adjust distance A from the top surface of the needle plate to the point of the left needle according to the gauge size in the table below. To make this adjustment, loosen nut B and move the needle bar up or down.

On W8042 and W8042-1, use the front needle for reference.

Gauge size		A (mm)
2-Needle	1/8	
	5/32	8.8
	3/16	8.2
	7/32	7.8
	1/4	7.4
3-Needle	7/32	7.8
	1/4	7.4
W8042		8.7
W8042-1		9.5
V7002-1S		9
W8103-1S		7.8

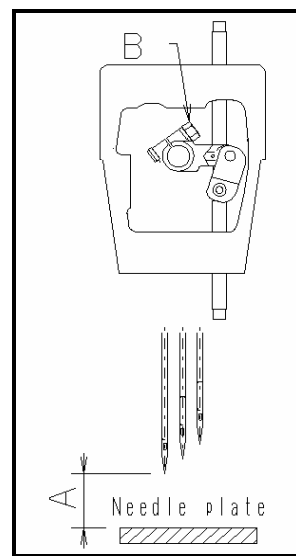

5-4 Length of the looper connecting bar

Adjust distance A between two connecting rods according to pitch A in the table below (see the illustration on the right). Adjustment is made by loosening nuts B and turning connecting bar C as required.

Model	Pitch A (mm)
V7100	100
W8100	100
W8042	102
W8042-1	105

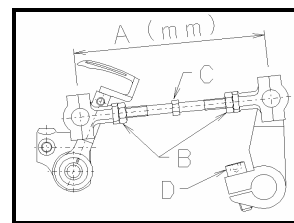

5-5 Loooper setting distance

Adjust setting distance A from the point of the looper to the center of the right needle when the looper is at the farthest position to the right. The point of the looper should be 1.2 - 1.5mm above the top of the left needle's eye when the point of the looper, moving to the right on the back side of the needles, has reached the left side of the left needle. Adjust distance A according to the needle space in the table below. Adjustment is made by loosening screw D (see the illustration in 5-4).

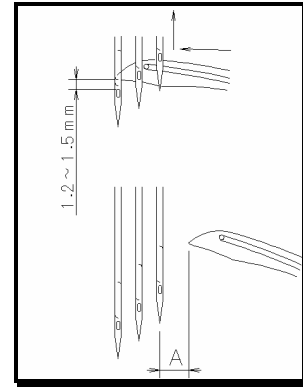

< Note >

On W8042 and W8042-1, use the front needle for reference.

Needle space (inch)	Looper setting distance A
3.2mm(1/8)	5.0mm
4.0mm(5/32)	4.6mm
4.8mm(3/16)	4.2mm
5.6mm(7/32)	3.7mm
6.4mm(1/4)	3.5mm
W8042	4.0mm
W8042-1	4.5mm

5-6 Needle/looper front-to-back relationship

The clearance between the right needle and the looper should be 0 - 0.05mm when the looper is moving on the back side of the needles. Adjustment is made by loosening screw A. The clearance between the left needle and the looper should be 0.2mm when the looper is moving on the back side of the needles.

Adjustment is made by loosening screws B on the eccentric. To increase the clearance, turn the eccentric backward.

To decrease the clearance, turn the eccentric forward

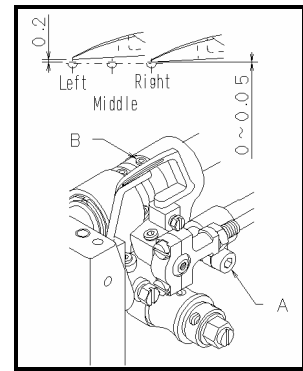

□6□ FRONT AND REAR NEEDLE GUARDS

6-1 Position of the needle guard (rear)

When the point of the looper has reached the center of the back side of the right needle, the distance from the point of the right needle to line A on the needle guard should be 0.8mm. At this time, there should be a 0mm clearance between the needle and the needle guard. The height adjustment is made with screws B. The front-to-back adjustment is made with screw C.

□ On W8042 (fixed type)

When the needle bar is at the bottom of its stroke, the distance from line A to the point of the needle should be 3mm. Adjustment is made by loosening screw D.

□ On W8042-1

When the point of the looper has reached the right side of the needle, the distance from line A to the point of the needle should be 1mm and the clearance between the needle and the needle guard should be 0mm. Adjustment is made by loosening screw E. The height adjustment is made with adjusting screw F.

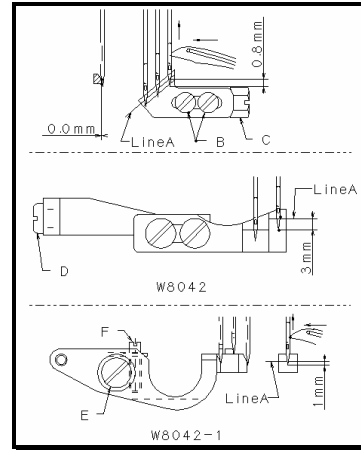

6-2 Position of the needle guard (front)

When the point of the looper has reached the center of the right needle, align the center of the right needle's eye with line A on the needle guard (front). Adjustment is made by loosening screw B.

The clearance between the needles and the needle guard (front) should be 0.2 - 0.5mm.

Adjustment is made by loosening screw C.

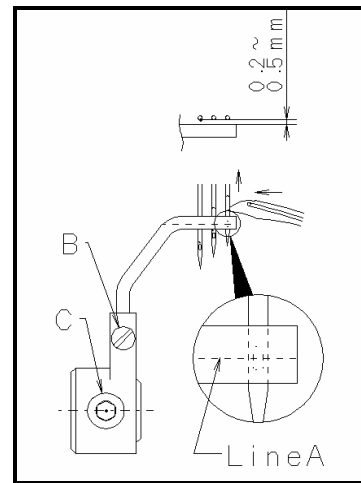

7 ADJUSTING THE FEED DOGS & STITCH LENGTH

7-1 Feed dog height

When the feed dogs are at the top of their stroke, the feed dog teeth should be 0.8 - 1.2mm above the top surface of the needle plate.

Adjustment is made by loosening screws A and B.

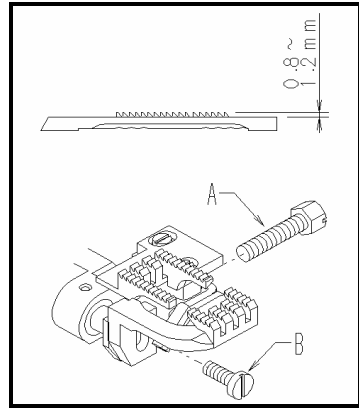

7-2 Stitch length

Loosen nut A with a 9.5mm T wrench and turn screw B as required. To increase the stitch length, turn screw B counterclockwise.

To decrease the stitch length, turn screw B clockwise.

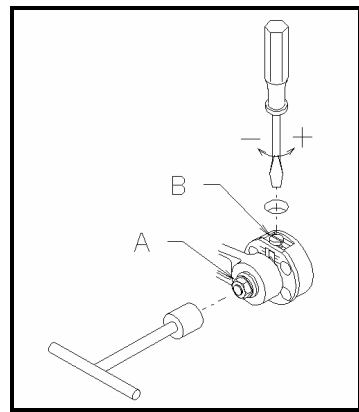

7-3 Differential feed ratio

Remove rubber plug C. Loosen nut D.

To increase the differential feed ratio, move nut D up. To decrease the differential feed ratio, move nut D down.

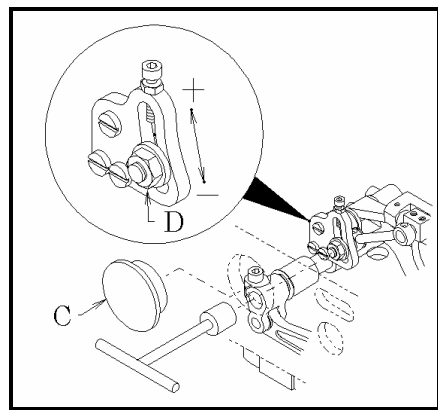

8 ADJUSTING THE SPREADER

8-1 Position of the spreader

The distance from the top surface of the needle plate to the bottom surface of the spreader should be 7 - 8mm. When the point of the thread carrying notch passes the left needle, the clearance between the point of the carrying notch and the left needle should be 0.5 - 1mm. With the spreader at the extreme left end of its travel, the distance from the center of the left needle to the point of the thread carrying notch should be 5-6.5mm.

Adjustments are made by loosening screws A and B.

- On W8042 and W8042-1

On these types of machines the needles are shifted front to back, so the threads are pushed backward by the auxiliary guide. With the spreader at the extreme left end of its travel, install the spreader correctly as shown in the illustration.

Adjustment is made by loosening screws C.

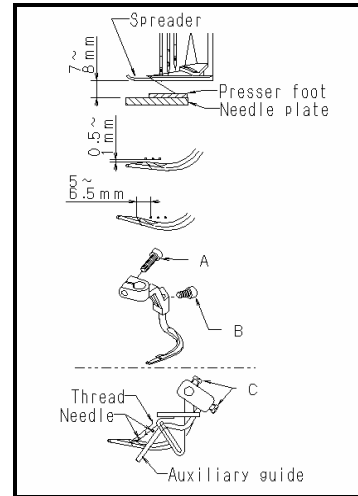

8-2 Position of the spreader thread eyelet

Set the clearance between spreader thread eyelet B and spreader A at 0.5 - 0.8mm.

With the spreader at the extreme right end of its travel, align point (a) of the spreader thread carrying notch with the center of the slot on the spreader thread eyelet. With the needle bar at the bottom of its stroke, set the clearance between spreader thread eyelet B and spreader thread eyelet C at 1mm and align the eye of spreader thread eyelet C with the center line of the slot on spreader thread eyelet B.

Adjustments are made by loosening four screws D and screw E and moving each spreader thread eyelet up or down, or left or right.

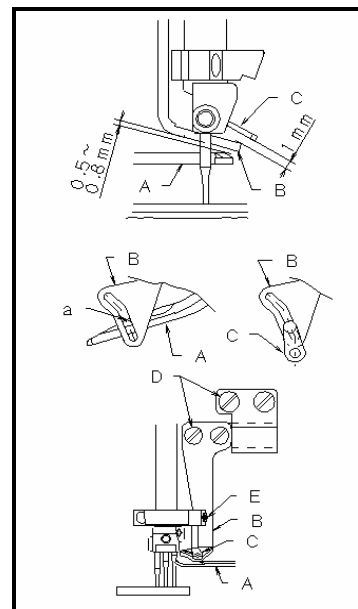

9 ADJUSTING THE PRESSER FOOT

9-1 Presser foot pressure

The presser foot pressure should be as light as possible, yet be sufficient to feed the fabric and produce uniform stitches.

To increase the presser foot pressure, turn the adjusting knob clockwise.

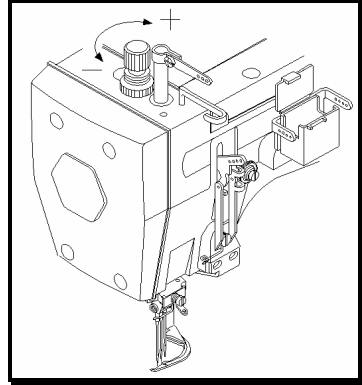

9-2 Position of the presser foot & foot lift

Fit the presser foot onto the presser bar so that the needle can drop correctly to the center of the presser foot needle drop hole.

□ Position of the presser foot

Loosen screw A. Adjust by moving the presser foot left or right while checking to make sure the needle drops correctly to the center of the presser foot needle drop hole.

□ Foot lift

For machines with the spreader, the presser foot should be 5mm above the top surface of the needle plate. Check to make sure presser foot does not touch the spreader with the presser foot in the above position. For machines without the spreader, the presser foot should be 6mm above the top surface of the needle plate.

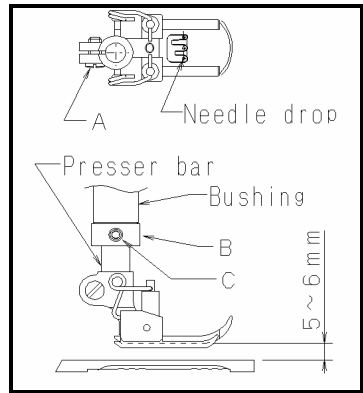

After the proper foot lift is achieved, fit collar B onto the presser bar bushing and tighten screw C.

□10□ADJUSTING THE STITCH FORMATION

10-1 Position of the needle thread eyelet

The distance from the center of the eyelet of the needle thread eyelet to that of set screw A should be approximately 16mm (see the illustration). Adjustment is made by loosening screw A and moving the thread eyelet up or down.

- To tighten the needle thread, move the thread guide up.
- To loosen the needle thread, move the thread guide down.

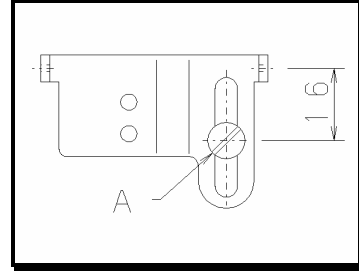

10-2 Position of the thread support

With the needle bar at the bottom of its stroke, the centers of the eyes on thread eyelet A should be level with the top surface of thread support B and thread eyelet A should be parallel with thread support B. Adjust the height of thread support B by loosening screw C and moving thread support B up or down.

- To tighten the needle thread, move it up.
- To loosen the needle thread, move it down.

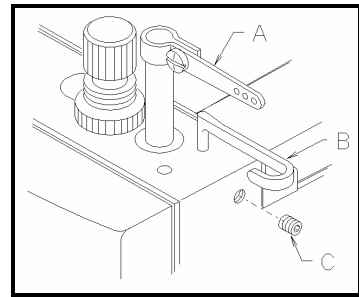

10-3 Position of the spreader thread eyelet

With the needle bar at the top of its stroke, there should be a distance of approximately 13mm from the center of the eye of thread eyelet A to part (a) on thread eyelet B. Adjustment is made by loosening screw C and moving thread eyelet A up or down.

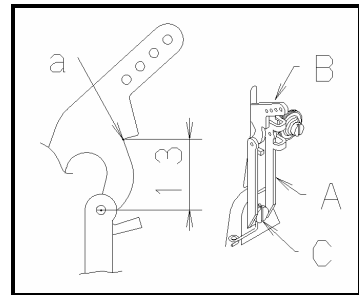

10-4 Position of the thread eyelet of the looper thread take-up

Align the eyes on thread eyelets B and C with mark (a) on guide plate A.

To increase the amount of looper thread to be supplied, move thread eyelets B and C to the back. To decrease the amount of looper thread to be supplied, move thread eyelets B and C to the front. Adjustment is made by loosening screws D.

Set the distance from the top surface of guide plate A to the bottom surface of thread guide E at 6-7mm. Adjustment is made by loosening screw F.

Adjust the thread eyelets of the thread take-up according to the thread and stitch length to be used.

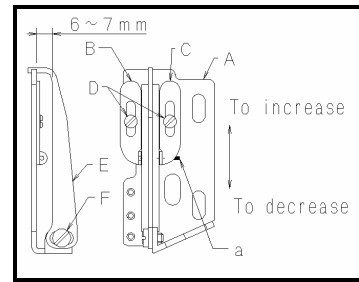

10-5 Position of the looper thread take-up

When the point of the left needle has reached the bottom surface of the looper blade while the looper is moving from the extreme left end of its travel, the looper thread should be removed properly from highest position B on thread take-up A.

Adjustment is made by loosening screw C.

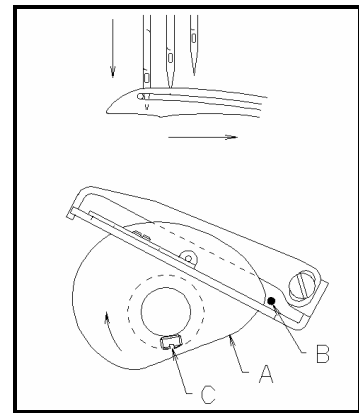

□ 11 □ CLEANING THE MACHINE

At the end of each day, remove the presser foot and the needle plate and then clean the slots of the needle plate and the area around the feed dogs.

