

INSTRUCTION

UF SERIES

Industrial Sewing Machines

WX8803/UF

RX9803/UF

MZ1103/UF

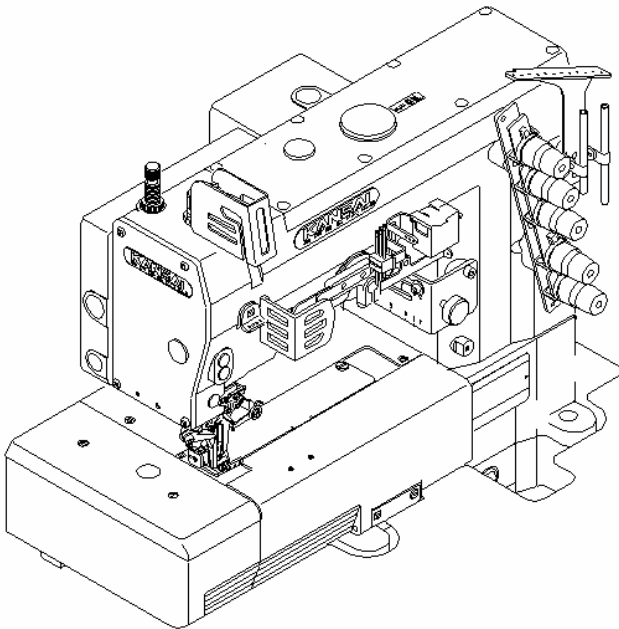

First published : May 1999

No. 990038

KANSAI
SPECIAL®

INTRODUCTION

Thank you for your purchasing Kansai Special's UF Series.

Read and study this instruction manual carefully before beginning any of the procedures and save it for later use.

1. This instruction manual describes adjustments and maintenance procedures for the Top-feed mechanism.
2. Before starting the machine, check to make sure the pulley cover, safety cover, etc. are secured.
3. Before adjusting, cleaning, threading the machine or replacing the needle, be sure to turn off the power.
4. Never start the machine with no oil in the reservoir.
5. Refer to the parts list of each model as well as this instruction manual before performing preventive maintenance.
6. The contents described in this instruction manual are subject to change without notice.

CONTENTS

1. Adjusting the amount of front-to-back movement on the top feed dog	
1-1 To adjust amount of front-to-back movement (stitch length) on the top feed dog in relation to the main feed dog	1
1-2 To adjust the clearance between the top feed dog and the main feed dog	2
1-3 To adjust the top feed dog pressure	2
2. Adjusting the top feed dog front to back	3
3. Adjust the top feed dog stroke	3
4. Adjusting the standard position of the top feed dog	4
5. Adjusting the top feed dog timing	6

1 ADJUSTING THE AMOUNT OF FRONT-TO-BACK MOVEMENT ON THE TOP FEED DOG

1-1 To adjust amount of front-to-back movement (stitch length) on the top feed dog in relation to the main feed dog

The main and top feed dogs separately move on this machine. Therefore, if the movement amount of the main feed dog is changed, that of the top feed dog should be changed.

The movement ratio of the top feed dog in relation to the main feed dog is one to one (standard). The symbols on scale serve as the reference for the amount of front-to-back movement on the top feed dog. S indicates 2mm. M indicates 4.5mm. L indicates 7mm.

C (CENTER): The top feed dog moves front to back in the divided-in-half mode.

B(BACK): The top feed dog moves front to back in the rear-fixed mode.

F(FRONT): The top feed dog moves front to back in the front-fixed mode.

- In the case of C or B

Adjust the amount of front-to-back movement with symbols on scale and mark on adjusting guide.

- In the case of F

Adjust the amount of front-to-back movement with symbols on scale and mark on adjusting guide. To increase the amount, turn knob clockwise.

To decrease the amount, turn knob counterclockwise. Adjust the amount while checking the stitch formation.

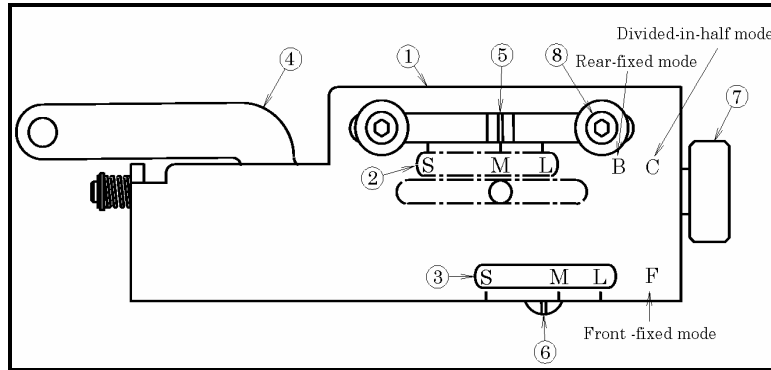

- To adjust the amount of front-to-back movement during sewing by means of a pedal and chain, knee switch, etc. (optional)

In the case of a pedal and chain:

Hook a chain over the end of lever (see the illustration).

To set the amount, move adjusting guide to the right by lowering lever (the amount is increased).

Loosen screws. Position the stopper while checking marks and on adjusting guide.

Then tighten screws. The amount can be increased up to mark L.

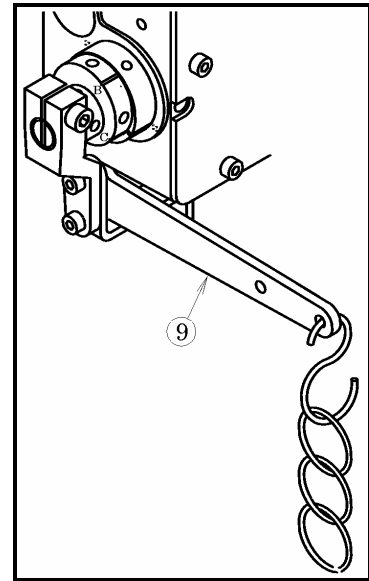

1-2 To adjust the clearance between the top feed dog and the main feed dog

To feed the fabric accurately according to sewing applications, types and/or thickness of the fabric, the top feed dog height adjustment should be made. With top feed dog at the bottom of its stroke and main feed dog at the top of its stroke, a piece of the fabric should be able to be placed between the top feed dog and the main feed dog when plain stitching is performed. Adjustment is made by loosening set screw on the top feed dog.

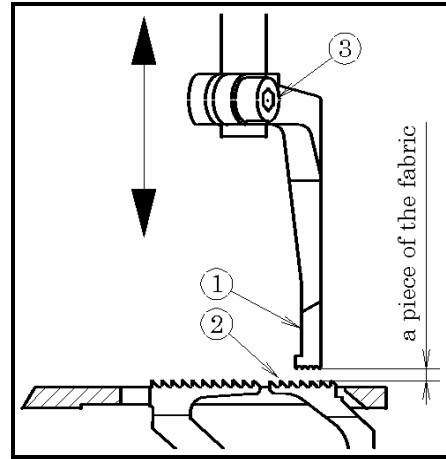

1-3 To adjust the top feed dog pressure

The pressure should be as light as possible, yet be sufficient to obtain the proper stitch formation and feed the fabric (see the illustration).

To increase the pressure, loosen lock nut and turn adjustment screw clockwise.

To decrease the pressure, loosen lock nut and turn adjustment screw counterclockwise.

The standard pressure can be achieved with a distance of 23mm from the top surface of lock nut to that of adjustment screw .

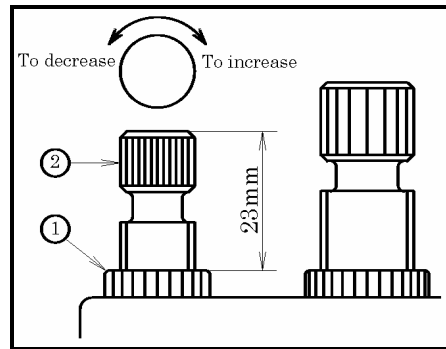

2 ADJUSTING THE TOP FEED DOG FRONT TO BACK

When top feed dog is at the extreme rear end of its travel with a maximum front-to-back movement amount of 7mm (=L), there should be a clearance of 1mm between top feed dog and the end of each slot on the presser foot. Adjustment is made by tightening set screw on front-to-back lever.

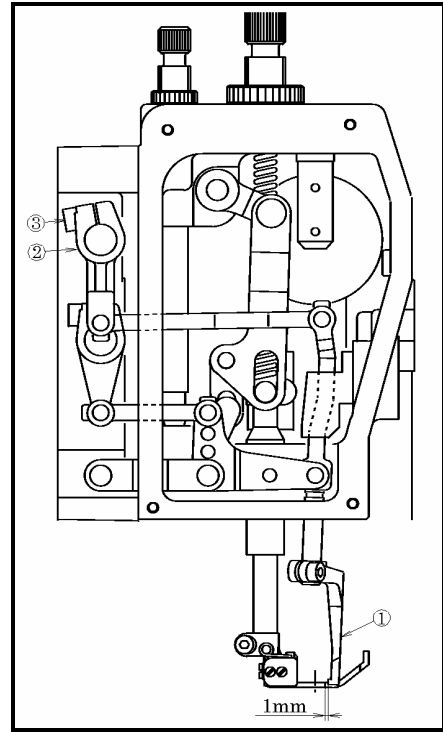
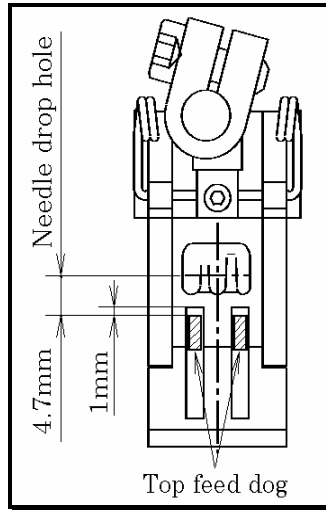

3 ADJUST THE TOP FEED DOG STROKE

To obtain a stroke of 4.7mm, remove the cover, loosen nut, move rod pin up or down and then align the center of rod pin with alignment mark on the center of the up-and-down shaft driven lever. To decrease the stroke, move up rod pin (min.:3.5mm). To increase the stroke, move down rod pin (max.:6.0mm).

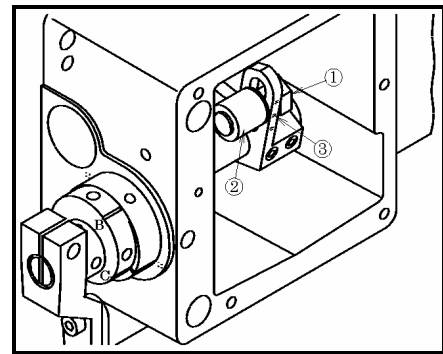
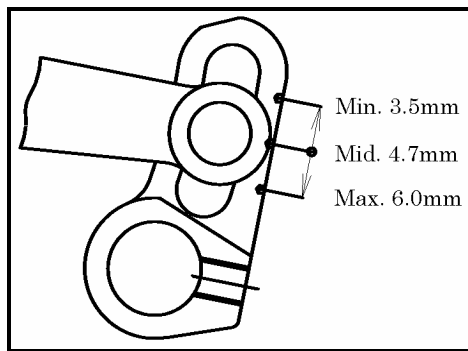

4 ADJUSTING THE STANDARD POSITION OF THE TOP FEED DOG

On this machine, the standard position of the top feed dog can be changed so that the fabric is accurately fed according to sewing applications, types and/or thickness of the fabric.

This feature eliminates plyshifting during sewing.

1. C (CENTER): The top feed dog moves in the divided-in-half mode.
This machine is factory-set in this mode.

2. B(BACK): The top feed dog moves in the rear-fixed mode.

3. F(FRONT): The top feed dog moves in the front-fixed mode.

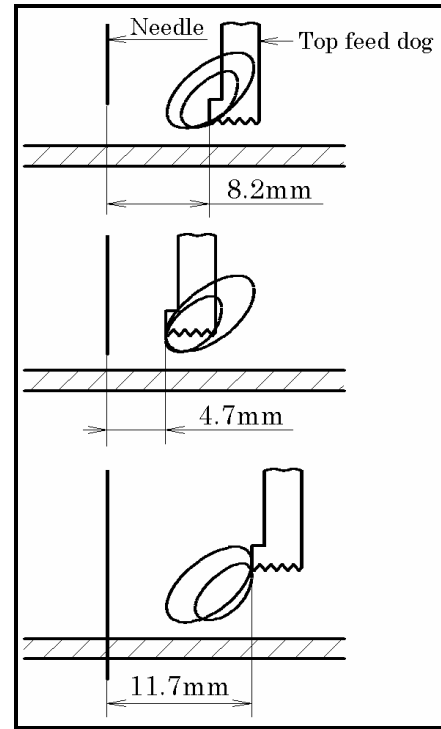

- Follow the precautions below before changing the standard position.

1. Bring the top feed dog to the extreme rear end of its travel.
2. Do not loosen screw □ on front-to-back movement adjusting lever □ and screw □ on the collar.

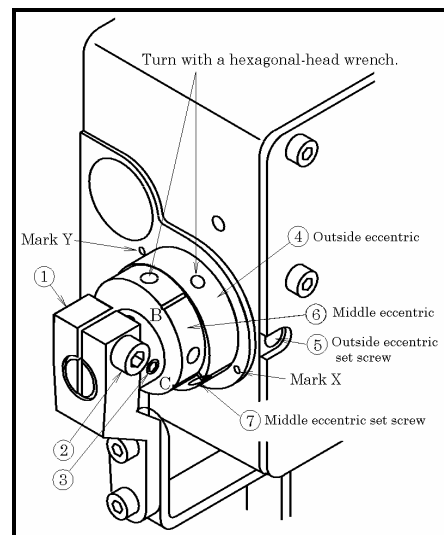

- The machine is factory-set at C.
 - The V-shaped groove on outside eccentric □ and inscription C on middle eccentric □ are aligned with mark X.
 - To change the standard position, follow the procedures below by referring to the illustrations as seen from the machine pulley.
- A. To change from C (CENTER) to B (BACK)
- 1). Loosen outside eccentric set screw □ first. Align the V-shaped groove on outside eccentric □ with mark X by turning outside eccentric □ and middle eccentric □ counterclockwise.
 - 2). Secure outside eccentric □ by tightening outside eccentric set screw □. Align inscription B on middle eccentric □ with mark Y by turning only middle eccentric □ 90□clockwise. Then tighten middle eccentric set screw □.

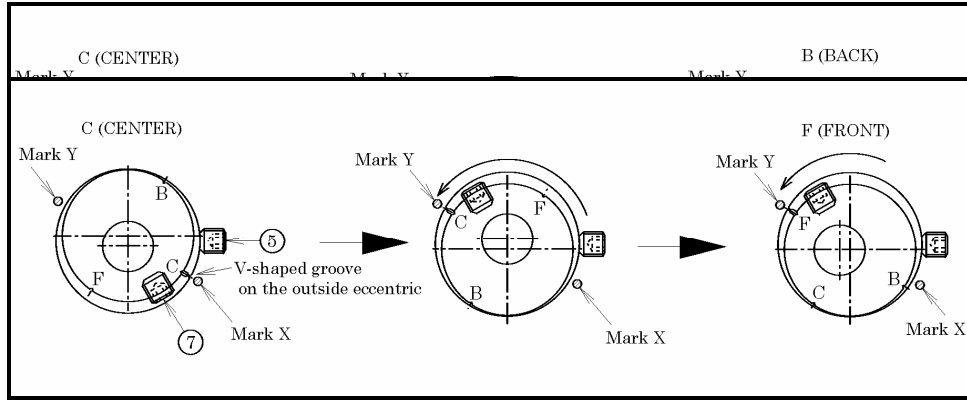

- B. To change from C (CENTER) to F (FRONT)
- 1). Loosen outside eccentric set screw □ first. Align the V-shaped groove on outside eccentric □ with mark Y by turning outside eccentric □ and middle eccentric □ counterclockwise.
 - 2). Secure outside eccentric □ by tightening outside eccentric set screw □. Align inscription F on middle eccentric □ with mark Y by turning only middle eccentric □ 90□counterclockwise. Then tighten middle eccentric set screw □.

- C. To change from B (BACK) to C (CENTER)
 Perform reverse procedures of No.1 (see below).

< Note >

Do not tighten excessively outside eccentric set screw □ and middle eccentric set screw □ (torque them to 15kg¥cm).

- 1). With outside eccentric □ secured, turn only middle eccentric □ 90□counterclockwise.
 - 2). Align the V-shaped groove on outside eccentric □ with mark X by turning outside eccentric □ and middle eccentric □ clockwise.
- D. To change from F (FRONT) to C (CENTER)
Perform reverse procedures of No.B (see below).
- 1). With outside eccentric □ secured, turn only middle eccentric □ 90□clockwise.
 - 2). Align the V-shaped groove on outside eccentric □ with mark X by turning outside eccentric □ and middle eccentric □ clockwise.
- E. To change from B (BACK) to F (FRONT)
Change B (BACK) to C (CENTER) first (follow procedure No.C).
Then change C (CENTER) to F (FRONT) (follow procedure No.B).
- F. To change from F (FRONT) to B (BACK)
Change F (FRONT) to C (CENTER) first (follow procedure No.D).
Then change C (CENTER) to B (BACK) (follow procedure No.A).

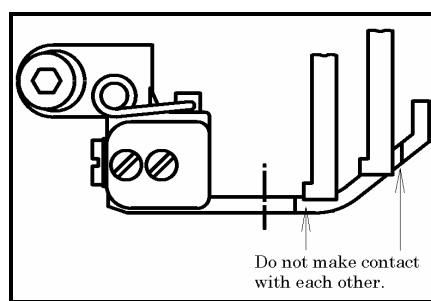

□5□ADJUSTING THE TOP FEED DOG TIMING

- To adjust the up-and-down timing
Align hole □ on the top feed up-and-down eccentric with V-shaped groove □ on the upper shaft (standard).
- To adjust the front-to-back timing
Align hole □ on the top feed front-to-back eccentric with V-shaped groove □ on the upper shaft (standard).

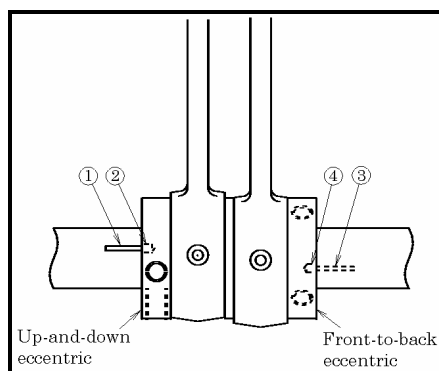

< Note >

The top feed dog path, height and front-to-back position are changed by changing the position of these holes and V-shaped grooves. Be careful.