

INSTRUCTION

www.kansai.org.ua

PX SERIES

Industrial Sewing Machines

PX302-4W

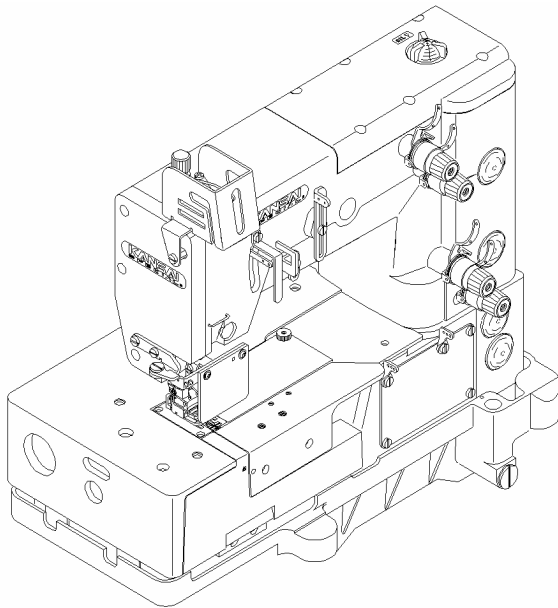

First published : July 1997

No. 970079

KANSAI
SPECIAL®

INTRODUCTION

Thank you for your purchasing Kansai Special's PX Series.

Read and study this instruction manual carefully before beginning any of the procedures and save it for later use.

1. This instruction manual describes adjustments and maintenance procedures on this machine.
2. Before starting the machine, check to make sure the pulley cover, safety cover, etc. are secured.
3. Before adjusting, cleaning, threading the machine or replacing the needle, be sure to turn off the power.
4. Never start the machine with any oil in the reservoir.
5. Refer to the parts list as well as this instruction manual before performing preventive maintenance.
6. The contents described in this instruction manual are subject to change without notice.

CONTENTS

1. NEEDLES & THREADING THE MACHINE	
1-1 Needles	1
1-2 Replacing the needle	1
1-3 To thread the machine	1
2. MACHINE SPEED	
2-1 Machine speed & direction in which the machine pulley runs	2
2-2 Motor & belt	2
3. LUBRICATION	
3-1 Oil	3
3-2 To fill the machine with oil	3
3-3 Replacing the oil and the filter element	3
4. SEWING MACHINE INSTALLATION	
4-1 Cutting the machine table	4
4-2 To install the machine	5
5. TIMING OF THE LOOPER TO THE NEEDLE	
5-1 Needle height	5
5-2 Needle drop and needle side stroke	6
5-3 To install the looper	6
5-4 Eccentric for adjusting the looper left to right	7
5-5 Position of the looper rocker	7
5-6 Looper left-to-right movement	8
5-7 Looper/needle front-to-back relationship	8
5-8 Looper setting distance	8
5-9 Adjusting the looper back spring	9
6. ADJUSTING THE NEEDLE GUARD	9
7. ADJUSTING THE FEED DOG & STITCH LENGTH	
7-1 Feed dog height	9
7-2 Stitch length	10
7-3 Differential feed ratio	10
8. ADJUSTING THE PRESSER FOOT	
8-1 Presser foot pressure	10
8-2 Position of the presser foot and foot lift	11
9. ADJUSTING THE STITCH FORMATION	
9-1 Adjusting the looper thread eyelets	11
9-2 Position of the looper thread take-up	12
9-3 Adjusting the needle thread guard	12
10. CLEANING THE MACHINE	12

1 NEEDLES & THREADING THE MACHINE

1-1 Needles

UO163 of Schmetz or Organ

Select the proper needle for the fabric and thread.

< Comparison table of needle sizes >

Schmetz	UY163GAS	Nm65	Nm70	Nm75	Nm80	Nm90
Organ	UO163	#9	#10	#11	#12	#14

1-2 Replacing the needle

When replacing the needle, check the needle carefully to see that the scarf is turned to the rear of the machine (see the illustration).

< Note >

When replacing the needle, be sure to turn off the machine. A clutch motor continues running for a while after the machine is turned off. Therefore keep on pressing the pedal until the machine stops.

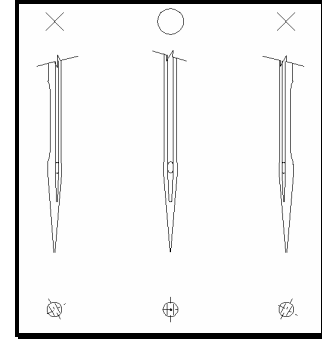

1-3 To thread the machine

Thread the machine correctly by referring to the illustration below. Incorrect threading may cause skip stitching, thread breakage and/or uneven stitch formation.

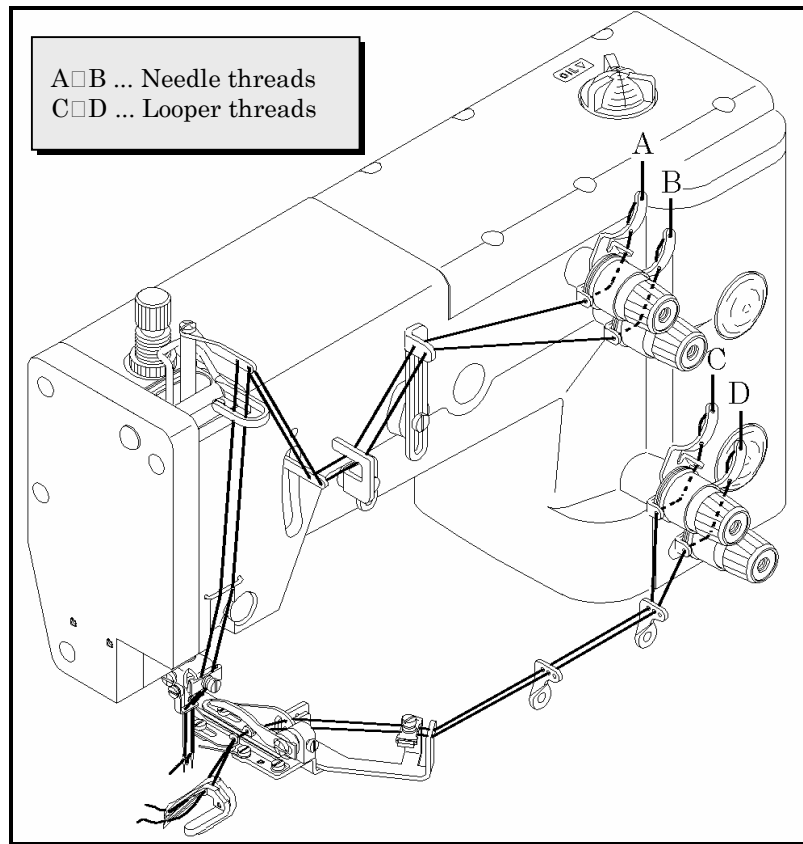

□2□MACHINE SPEED

2-1 Machine speed & direction in which the machine pulley runs

Maximum speed : 3,500 rpm

Standard speed : 3,000 rpm

To extend machine life, run the machine approximately 15~20% below the maximum speed for the first 200 hours of operation (approx. 1 month).

Then run the machine at the standard speed.

The machine pulley turns counterclockwise as seen from the end of the machine pulley (see the illustration).

2-2 Motor & belt

Motor : 3-phase, 2-pole, 400W clutch motor

Belt : M type V belt

Select the proper motor pulley according to the machine speed (refer to the motor pulley outer diameter on the table below). Adjust the position of the motor by pressing the finger onto the middle of the belt so that 1~2cm deflection can be achieved (see the illustration).

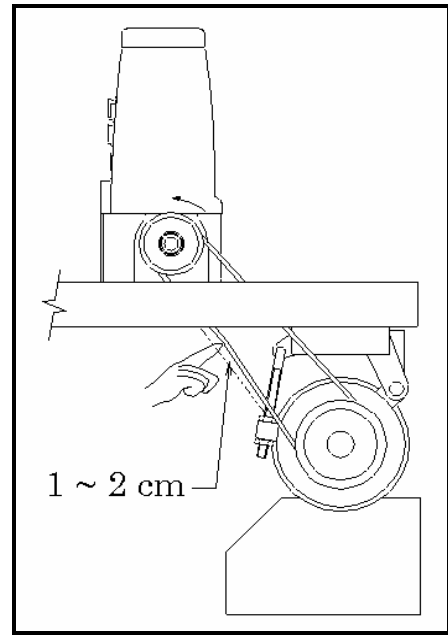

< Motor pulley selection table >

Motor pulley outer diameter (mm)	Machine speed (SPM)	
	50Hz	60Hz
60	2500	2950
70	2900	3450
80	3300	(3900)
90	(3700)	(4400)

3 LUBRICATION

3-1 Oil

Use Kansai Special's genuine oil
(Part No. 28-611)

3-2 To fill the machine with oil

Remove oil plug A. Fill the machine with oil until the oil level is at the top line (see H in the illustration) on oil gauge C. After the first lubrication, add oil so that the oil level will be between H and L. After filling the machine with oil, tighten plug A and run the machine to check the oil is splashing from oil pipe outlet B.

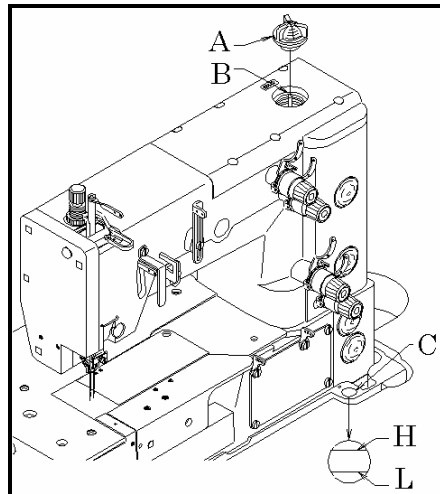

3-3 Replacing the oil and the filter element

To extend machine life, be sure to replace the oil after the first 250 hours of operation.

To replace the oil, follow the procedures below.

1. Remove the V belt from the motor pulley and then remove the machine from the table.
2. Remove screw D and then drain the oil. Be careful not to stain V belt with the oil.
3. After draining the oil, be sure to tighten screw D.
4. Fill the machine with oil by referring to 3-2 shown above.

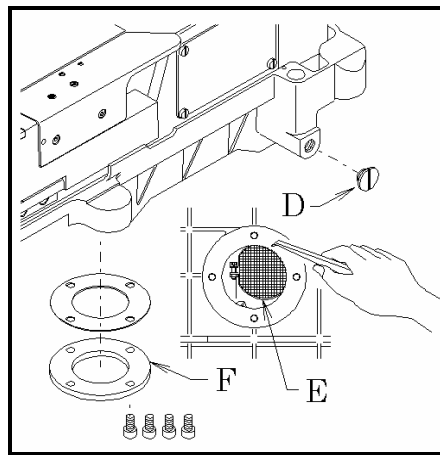

If filter element E is contaminated, proper oiling may not be performed. Clean the filter element every six months. If just a little or no oil flows out from the nozzle with the proper amount of oil in the machine, check the filter element.

To clean the filter element, remove oil filter cap F.

< Note >

When the oil filter cap is removed, the oil collected on the filter element drips.
Be careful.

4 SEWING MACHINE INSTALLATION

4-1 Cutting the machine table

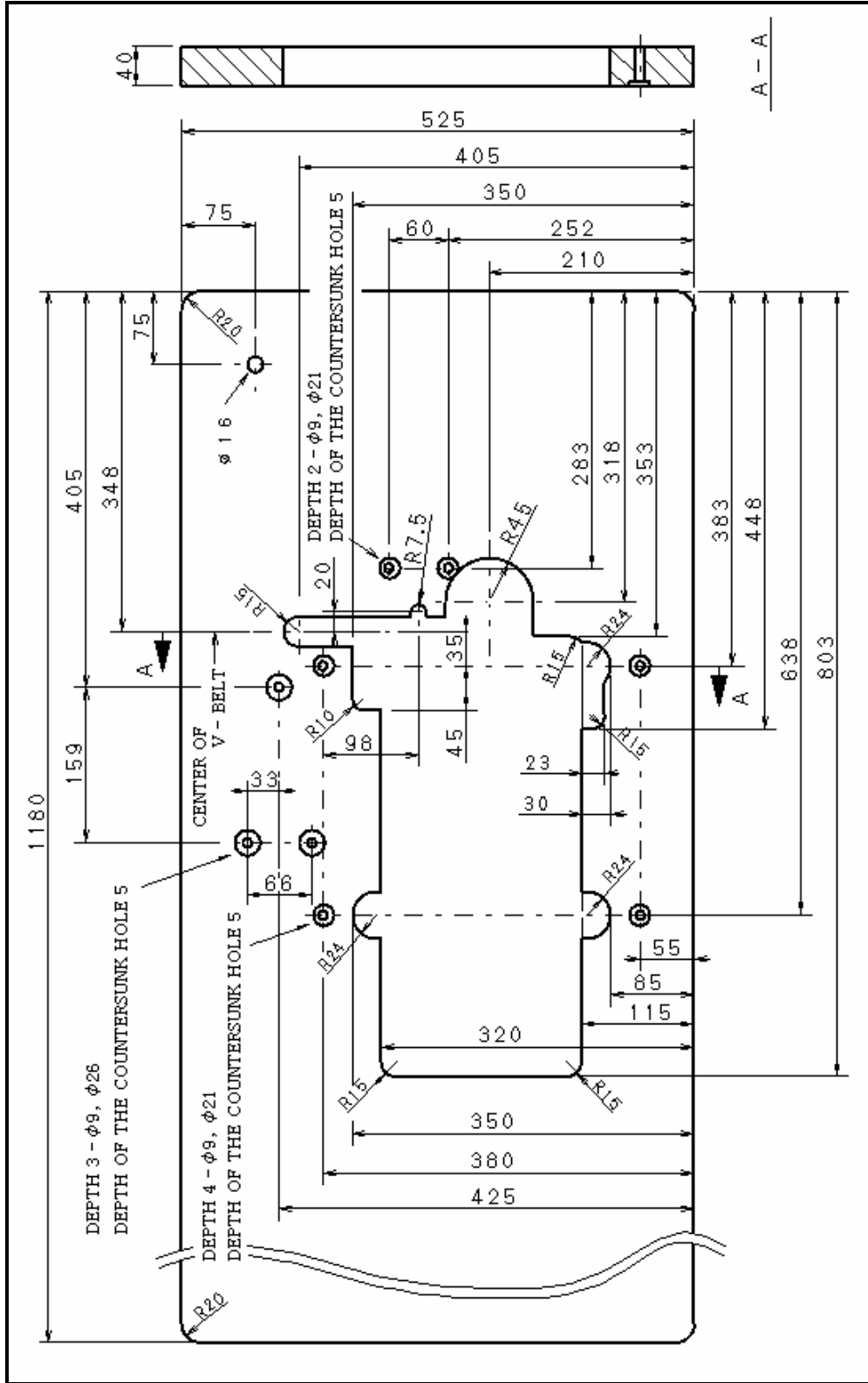

4-2 To install the machine

Install the brackets on the underside of the table board (see the illustration below).

Fit the rubber cushions onto the brackets.

Mount the machine head on the rubber cushions correctly.

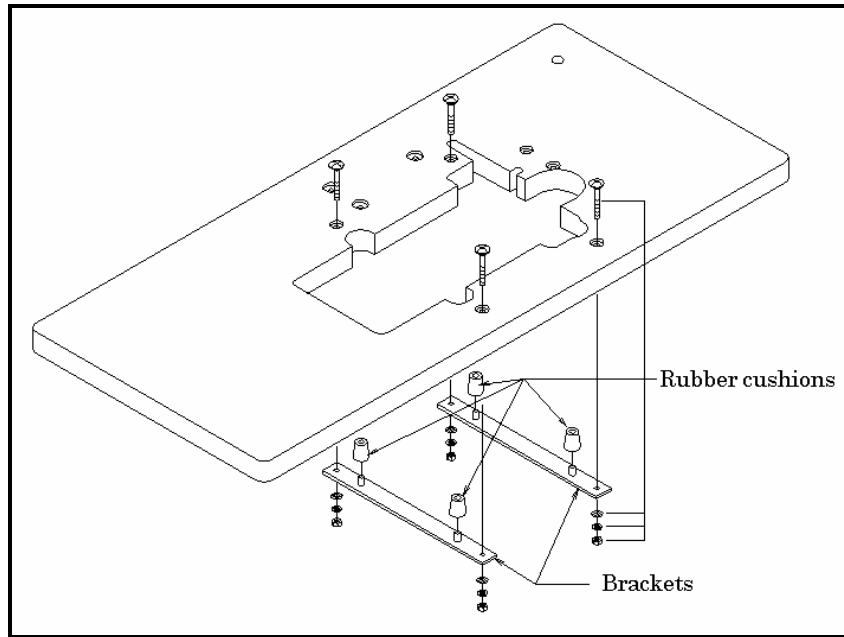

5 TIMING OF THE LOOPER TO THE NEEDLE

5-1 Needle height

When the needle bar is at the top of its stroke, there should be a distance of 10mm from the top surface of the needle plate to the point of the needle.

Adjustment is made by loosening screws A.

< Note >

After the above adjustment is made, check to make sure each needle drops correctly into the center of each needle drop hole.

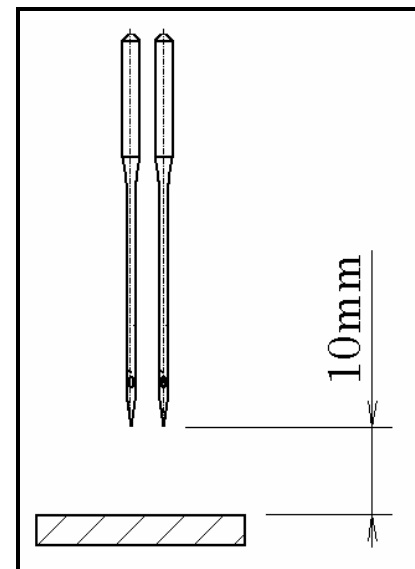

5-2 Needle drop and needle side stroke

The needle side stroke on this machine is 5.55mm. To increase the stroke, loosen screw B and move it up in the slot. To decrease the stroke, loosen screw B and move it down in the slot. The point of the needle should be centered left to right between fingers of the needle plate when the needle drops to the needle plate. Adjustment is made by loosening screw C.

The needle side stroke movement should start when the point of the needle moves up from the top surface of the needle plate. The needle side stroke movement should stop when the point of the needle reaches the top surface of the needle plate. This timing adjustment is made by worm gear D. To adjust the position of the needle drop, loosen screws A and turn the needle bar as required.

< Note >

Position of the needle drop 1, 2, 3, 4 from the right side 4 is the extreme left end.
4, 5, 6, 1 from the left side

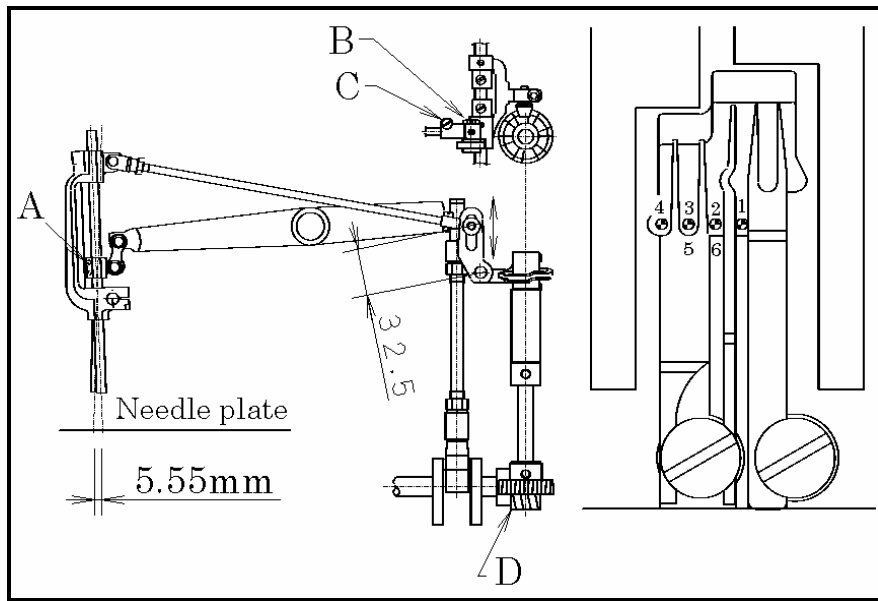

5-3 To install the looper

To set the angle and height of the looper, insert the looper fully into looper holder A and tighten screw B.

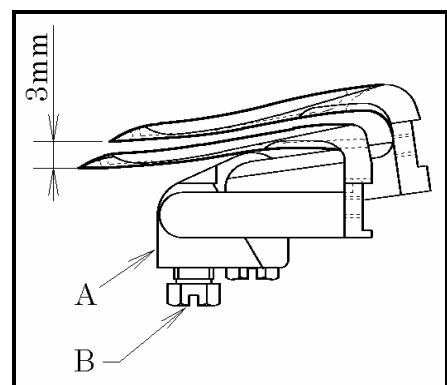

5-4 Eccentric for adjusting the looper left to right

To adjust the position of the eccentric, loosen screws D. Align the screw which comes second in the turning direction of the eccentric with the mark on the shaft. Then tighten screws D temporarily. Then make a fine adjustment so that the looper shaft can reach the extreme right end of its travel while the needle is at the bottom of its stroke with position 1. After this adjustment, tighten the screws securely.

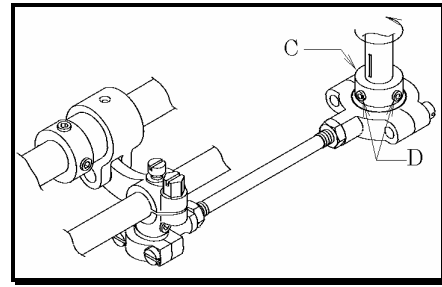

5-5 Position of the looper rocker

The setting distances of the looper with the needle at position 1 and position 4 should be equal (5.5mm) (see 5-2). To achieve this adjustment, loosen screw A to loosen the collar. Loosen screws B and C. Then adjust looper rocker D and lever E.

□ Example

If the setting distance with the needle at position 1 is 5mm and the setting distance with the needle at position 4 is 6mm, move looper rocker D approximately 1mm to left. After the adjustment is made, tighten screws B and C securely. Then tighten screw A with the collar fitted onto looper rocker D.

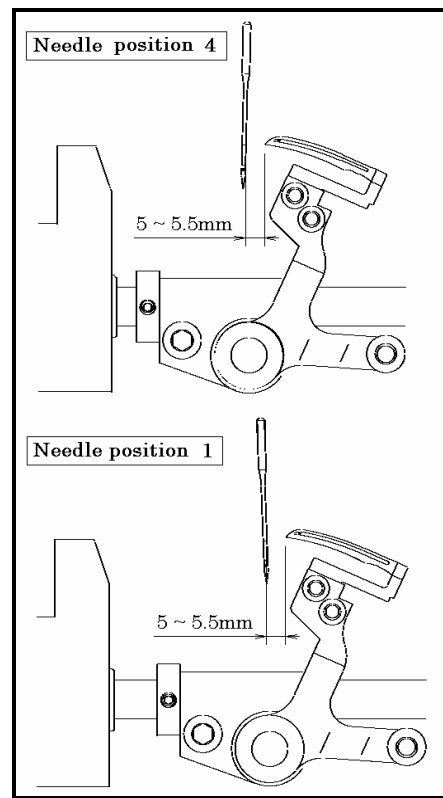
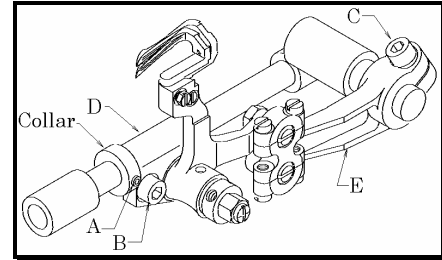

5-6 Looper left-to-right movement

This adjustment should be made when the needle is at position 4 (see 5-2). When the point of the looper, moving to the left, has reached the left side of the needle, it should be 1mm above the top of the needle's eye. When the point of the looper, moving to the right, has reached the left side of the needle, it should be 0.2mm above the top of the needle's eye.

The looper moves 0.8mm faster than the needle (see the illustration on the right).

Adjustment is made by loosening three screws F.
After the adjustment, tighten these three screws equally.

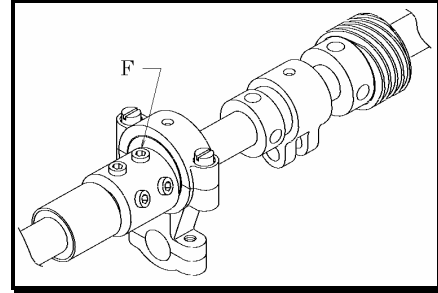
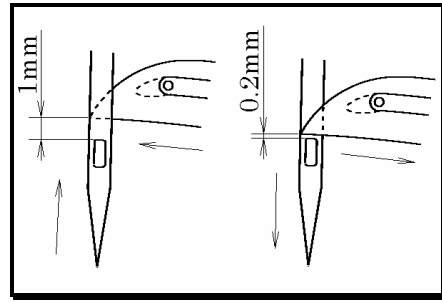

5-7 Looper/needle front-to-back relationship

Adjust when the needle is at position 3 or 5 (see 5-2).

When the point of the looper is at the center of the needle, there should be a clearance of 0mm between the needle and the looper.

Adjustment is made by loosening screw A.

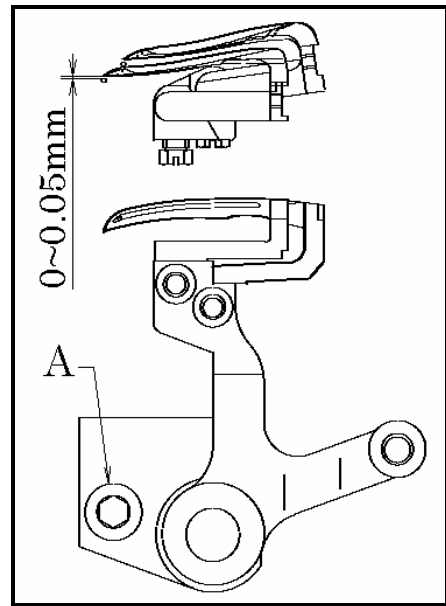

5-8 Looper setting distance

Check the looper setting distance by referring to the table below.

If the looper setting distance is not correct, perform 5-4, 5-5 procedure again.

Needle position	Setting distance (mm)
1, 4	5.5
2, 6	5.8
3, 5	4.7

5-9 Adjusting the looper back spring

It is the best that the surface of the spring touches the looper closely within the range of B.

Check to see if the surface of the spring touches the looper closely at least on points C within the range of B.

Spun thread #60 should be removed from the spring at approximately 80~100g of tension.

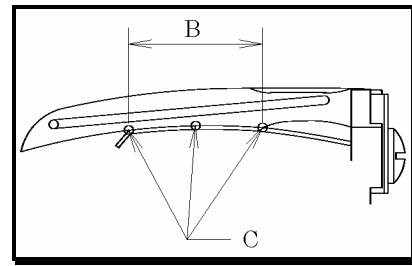

6 ADJUSTING THE NEEDLE GUARD

This adjustment should be made when the needle is at position 4 (see 5-2). When the point of the looper, moving to the left, has reached the right side of the needle, line A on the needle guard should be 0.3~0.5mm above the point of the needle (see the illustration on the right). Then the needle must slightly touch the needle guard. Adjustment is made by loosening screw B.

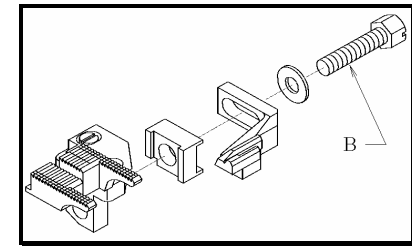
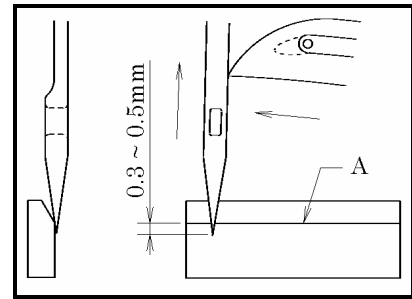

7 ADJUSTING THE FEED DOG & STITCH LENGTH

7-1 Feed dog height

When the feed dog is at the top of its stroke, the feed dog teeth should be 0.8~1.2mm above the top surface of the needle plate. Adjustment is made by loosening screws A and B.

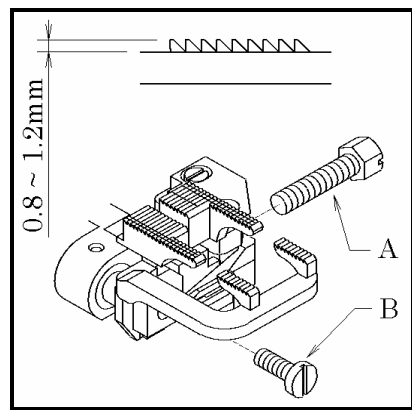

7-2 Stitch length

Loosen nut A with a 9.5mm T-wrench.

Then turn screw B as required.

To decrease the stitch length, turn it clockwise.

To increase the stitch length, turn it counterclockwise (see the illustration on the right).

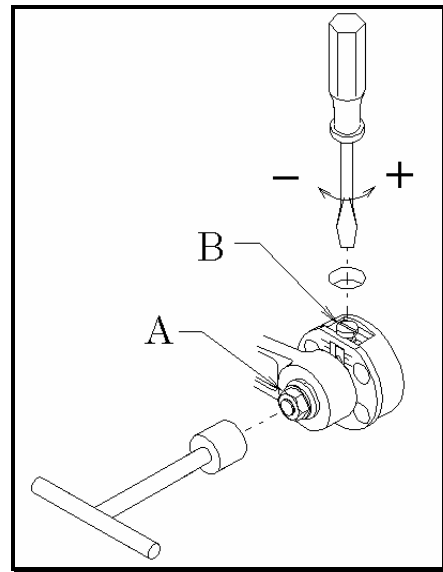

7-3 Differential feed ratio

Remove rubber plug C. Loosen nut D.

To increase the differential feed ratio, move up the nut. To decrease the differential feed ratio, move down the nut.

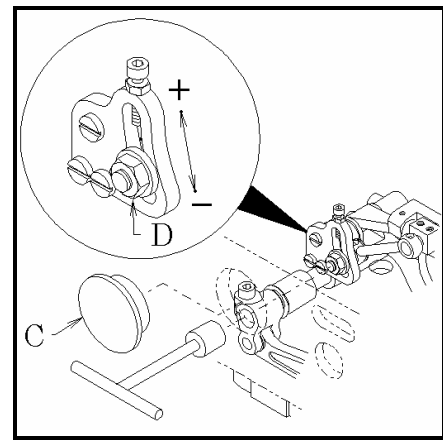

8 ADJUSTING THE PRESSER FOOT

8-1 Presser foot pressure

The presser foot pressure should be as light as possible, yet be sufficient to feed the fabric and produce uniform stitches. To increase the presser foot pressure, turn the adjusting knob clockwise (see the illustration on the right).

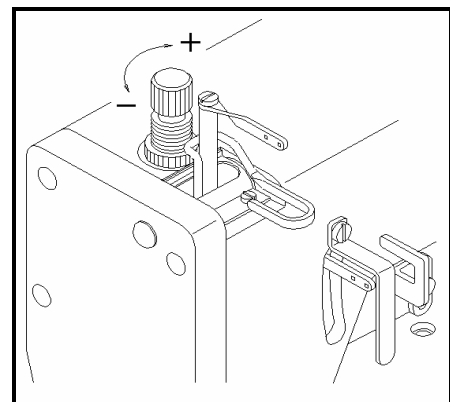

8-2 Position of the presser foot and foot lift

The presser foot should not touch the needle.

Adjustment is made by loosening screw A and then moving the presser foot to the right or left.

□ Foot lift

Fit the collar onto the bushing with the presser foot 9mm above the top surface of the needle plate.

Then tighten screw B.

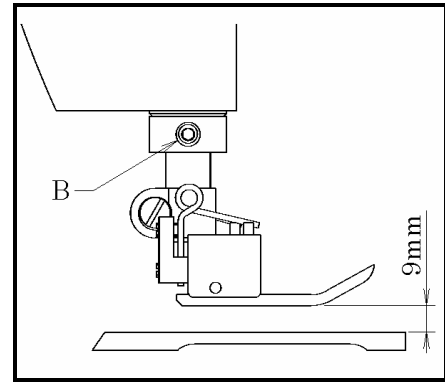
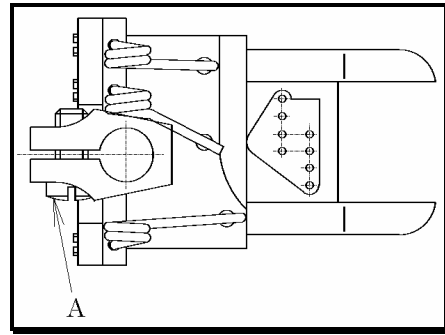

□9□ADJUSTING THE STITCH FORMATION

9-1 Adjusting the looper thread eyelets

Align the eyes on the looper thread eyelets A with the center line of the shaft. Adjust looper thread eyelets A according to sewing conditions such as the fabric or thread to be used by loosening screws B.

To increase the amount of the thread to be supplied, move the eyelets backward. To decrease the amount of the thread to be supplied, move the eyelets forward. Thread guide C should be 6~7mm above the guide plate. Adjustment is made by loosening screw D.

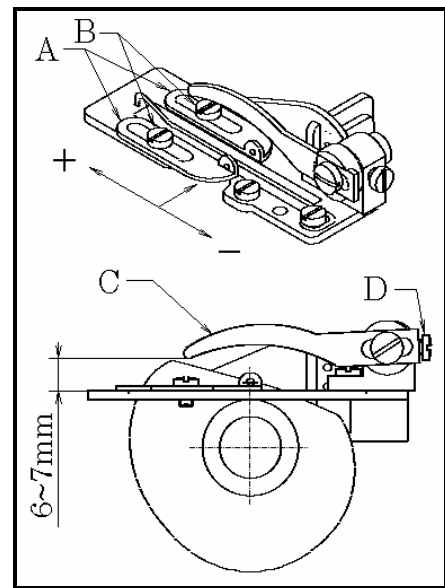

9-2 Position of the looper thread take-up

When the bottom of the needle's eye has reached the top surface of the needle plate while the needle is descending, the looper thread taken up by looper thread take-up E should be removed from the looper thread take-up at point F. Adjustment is made by screw G.

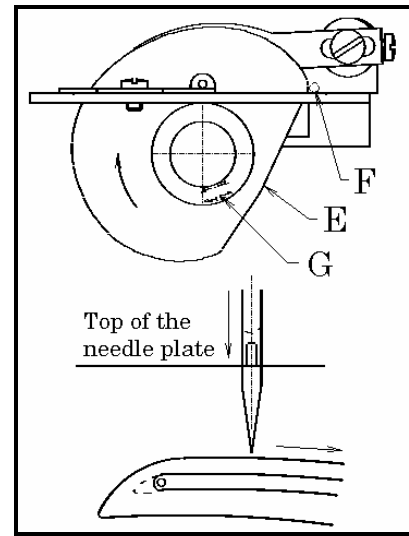

9-3 Adjusting the needle thread guard

With the needle bar at the bottom of its stroke, the centers of eyes on needle bar thread eyelet A should be level with the top surface of needle thread guard B. Adjustment is made by screw C.

To tighten the needle thread, move up needle bar thread eyelet A. To loosen the needle thread, move down needle bar thread eyelet A.

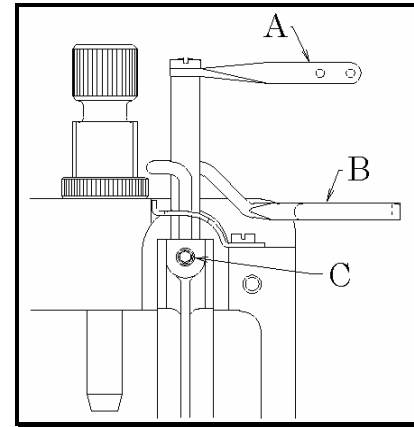

10 CLEANING THE MACHINE

At the end of each day, remove the presser foot and the needle plate and then clean the slots of the needle plate and the area around the feed dogs.

