

INSTRUCTION

MZ/UTC MANUAL

www.kansai.org.ua

MZ SERIES

Industrial Sewing Machines

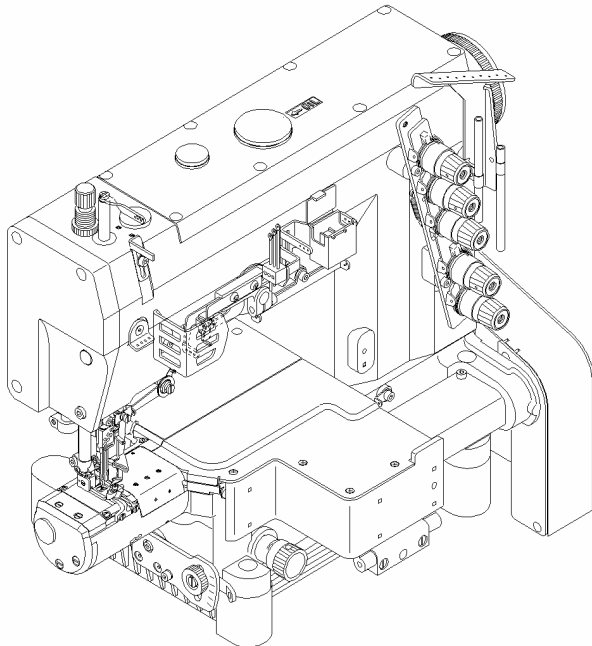

*First published : May 1997
Fourth edition : January 1999*

No. 980101

KANSAI
SPECIAL®

INTRODUCTION

Thank you for your purchasing Kansai Special's MZ/UTC Series.

Read and study this instruction manual carefully before beginning any of the procedures and save it for later use.

This instruction manual describes adjustments and maintenance procedures for the thread trimmer.

Refer to the MZ Series instruction manual for other information.

CONTENTS

1. HOW TO USE THE THREAD TRIMMER	1	10. ADJUSTING THE PRESSER FOOT LIFT	9
2. INSTALLING THE POSITION DETECTOR	1	11. ADJUSTING THE TOP COVER THREAD TRIMMER	
3. ADJUSTING THE THREAD TRIMMER AIR CYLINDER		11-1 Relationship between the position of the movable knife and the stationary knife	10
3-1 Air cylinder stroke	2	11-2 Adjustment the top cover thread clamp spring and the movable knife pressure spring	10
3-2 Air cylinder return spring	2	11-3 The top cover thread trimmer installation	11
4. ADJUSTING THE THREAD TRIMMER SOLENOID		11-4 Adjusting the top cover thread releaser hook	11
4-1 Solenoid stroke	2	12. WIRING AND PIPING FOR PNEUMATIC DEVICES	
4-2 Adjusting the solenoid return spring	2		12
5. ADJUSTING THE THREAD TRIMMER		13. WIRING AND PIPING FOR ELECTRIC DEVICES	
5-1 Position of the movable knife and the stationary knife	3		12
5-2 Adjusting the looper thread clamp spring	3		
5-3 Adjusting the movable knife pressure spring	3		
5-4 Adjusting the stationary knife holder stopper	4		
5-5 Adjusting the movable knife holder left and right	4		
5-6 Adjusting the movable knife front to back	4		
5-7 Relationship between the movable knife, needle thread and looper thread	5		
5-8 Looper thread clamp spring pressure	5		
6. ADJUSTING THE THREAD RELEASER			
6-1 Thread releaser block	6		
6-2 Thread releaser connection plate	6		
6-3 Thread releaser lever	6		
6-4 Thread releaser plate	7		
6-5 Thread releaser hook	7		
7. SAFETY DETECTOR	7		
8. ADJUSTING THE SPEED CONTROLLER AND AIR PRESSURE	8		
9. THREAD WIPER ADJUSTMENT	8		

【1】 HOW TO USE THE THREAD TRIMMER

< Note >

Do not use this thread trimmer with no fabric under the presser foot.

- Pressing the pedal with toe (position A) starts the machine.
Releasing the pedal (position B) stops the needle at the top/bottom of its stroke (adjustable with the motor).
- If the needle stops at the bottom of its stroke as adjusted, pressing the pedal with heel (position C) raises the needle. As soon as the needle stops at the top of its stroke by pressing the pedal with heel, the thread trimmer gets actuated (if the needle stops at the top of its stroke as adjusted, the thread trimmer gets actuated by pressing the pedal with heel).
- Returning the pedal to position B lowers the presser foot.
- The presser foot can be raised or lowered freely by releasing the pedal (position B) or pressing the pedal with heel (position C) until the pedal is placed at position A for the next sewing operation after the threads are cut.

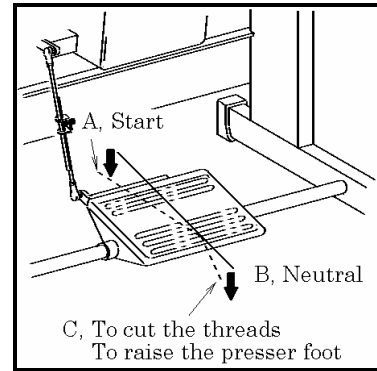

【2】 INSTALLING THE POSITION DETECTOR

- Install position detector A and tighten screw B temporarily.
- Fit positioner bar C onto the guide groove of the position detector. Then tighten screw D.
- Turn on the motor.

< Note >

*Remove the connector for the thread trimmer cylinder.
Make sure the knife is retracted all the way.*

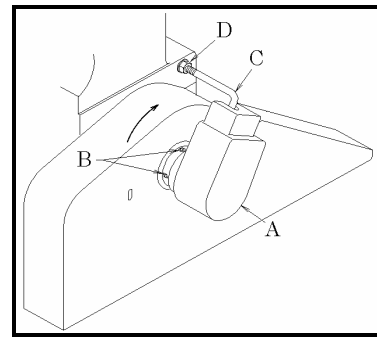

- Press the pedal with heel after two to three stitches are formed by pressing the pedal with toe. Then the needle stops.
- Loosen screws B for the position detector. Turn the machine pulley while checking that the position of screws B is not shifted. Align mark P on handwheel E with the alignment mark on the arm. Then the needle bar is at the top of its stroke. Tighten screws B to secure the position detector.
- Check to see if the needle bar stops at the top of its stroke by pressing and then releasing the pedal.

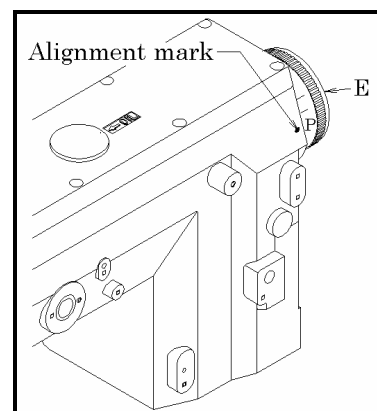

【3】 ADJUSTING THE THREAD TRIMMER AIR CYLINDER

3-1 Air cylinder stroke

The stroke of the air cylinder should be approximately 15mm.

To adjust this stroke, loosen collar B and screw A. Set the clearance between rubber cushion F and the rear end of the cylinder at 15mm.

To position shaft E, loosen nut C.

With the cylinder retracted, set the distance from the left end of cylinder installation bracket D and the center of shaft E at approximately 57.3mm.

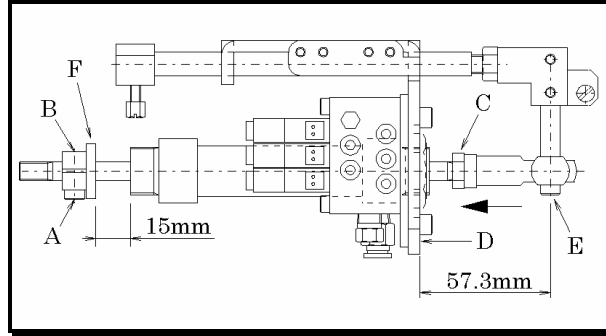

3-2 Air cylinder return spring

With the cylinder plunger protruded, there should be approximately 26mm clearance between ring G and bracket D.

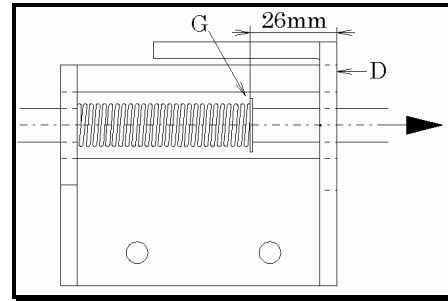

【4】 ADJUSTING THE THREAD TRIMMER SOLENOID

4-1 Solenoid stroke

The stroke of the solenoid should be approximately 15mm.

To adjust this stroke, remove rubber cover F and loosen nut A.

Set the clearance between rubber cushion B and the rear end of the solenoid at 15mm. To position shaft E, loosen nut C. With the solenoid retracted, set the distance from the left end of bracket D and the center of shaft E at approximately 57.3mm.

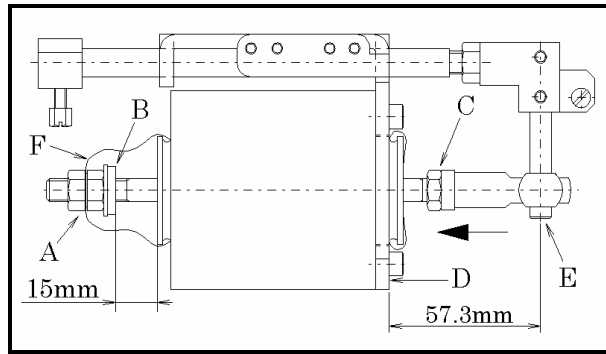

4-2 Adjusting the solenoid return spring

With the solenoid plunger protruded, there should be approximately 42mm clearance between collar H and bracket D. To make this adjustment, loosen screw G of solenoid return spring collar H.

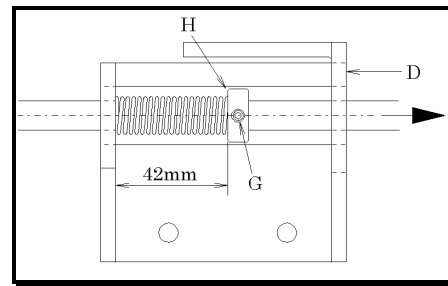

【5】 ADJUSTING THE THREAD TRIMMER

5-1 Position of the movable knife and the stationary knife

■ Position of the movable knife

Set the (a 1) part of the movable knife A parallel to the (g 1) part of the stationary holder G.

Set the distance from point of movable knife A and the center of left screw H at approximately 73.5mm.

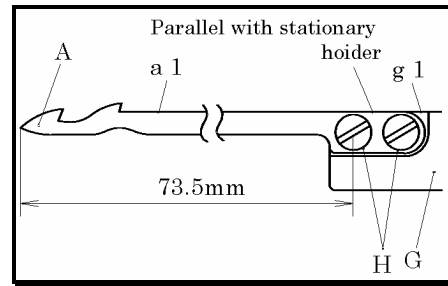

■ Relation between the stationary knife and the movable knife.

Adjust the engagement between blade (a 3) for trimming looper thread and stationary knife to be 0.5mm when movable knife is at the extreme right.

So that the point of blade (a 2) for cutting needle thread pass the corner (b 1) of stationary knife B.

The adjustment is made by loosening screw C.

Note that the looper thread clamp spring is simultaneously loosened.

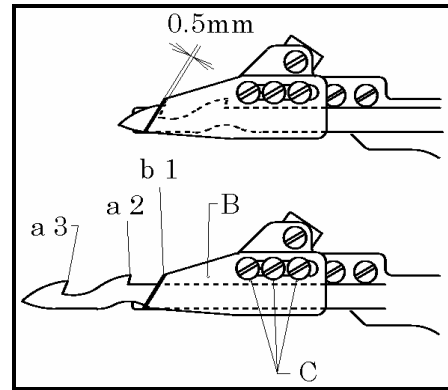

5-2 Adjusting the looper thread clamp spring

Position of looper thread clamp spring D so that the part (a 1) of movable knife and the part (d 1) of looper thread clamp spring are on the same plane.

And adjust it will protrude approximately 2.2mm from the point of movable knife A when movable knife is at the extreme right. Adjustment is made by loosening screw C.

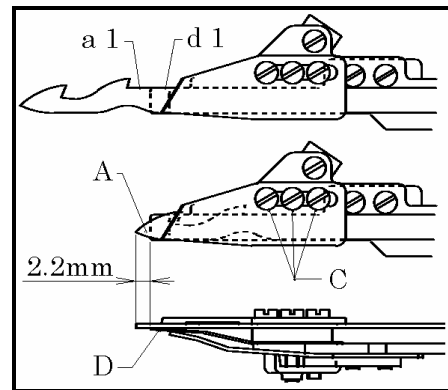

5-3 Adjusting the movable knife pressure spring

Position of movable knife pressure spring F so that the part (a 1) of movable knife and the part (f 1) of movable knife pressure spring are on the same plane.

And adjust it will protrude approximately 5.2mm from the point of movable knife A when movable knife is at the extreme right. Adjustment is made by loosening screw E.

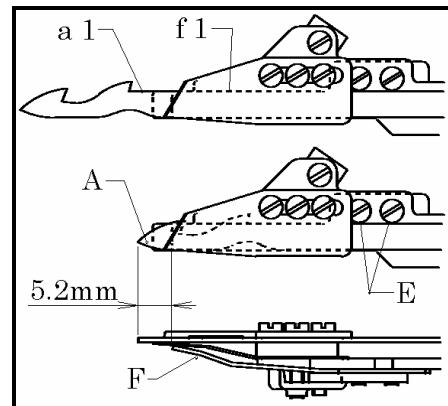

5-4 Adjusting the stationary knife holder stopper

When stationary knife holder I moves left and part (m 1) of drive lever M meets the left end of ring guide (L 1), stationary knife holder stopper J is touched stationary knife holder and stopped.

The adjustment is made by loosening screw K and moving stationary knife stopper left and right.

The standard position, the left end of stationary knife holder stopper is 1mm right from the left end of base plate R.

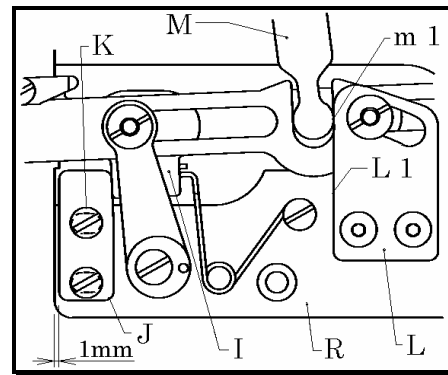

5-5 Adjusting the movable knife holder left and right

With movable knife A at the extreme left end of its travel, there should be a distance of 22mm from the center of the needle bar to the point of movable knife A.

To make the above adjustments, remove pin S and make a fine left-to-right adjustment on movable knife driver lever M by turning screw T.

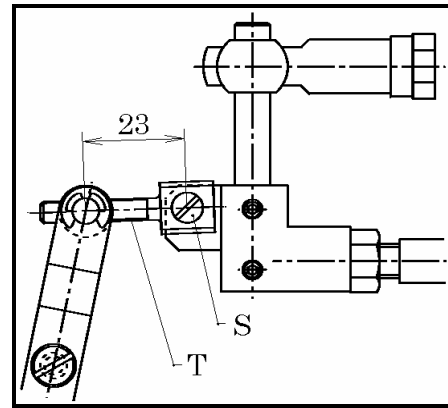
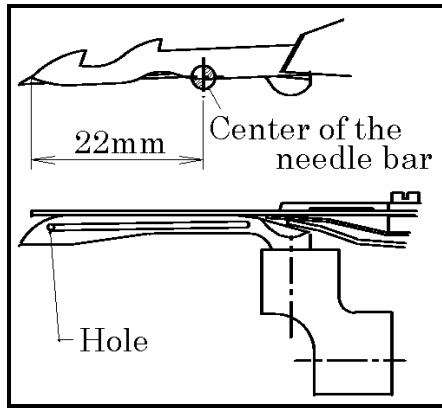

5-6 Adjusting the movable knife front to back

To adjust the movable knife front to back, center the point of movable knife over the looper with the point of movable knife 12mm moved to the left from the right end of looper.

To adjust, when loosening screw U and turning guide lever ring P clockwise, the movable knife point moves forward and turning it counterclockwise, the point moves backward.

At the same time, movable knife holder guide N should slightly touch the end of movable knife holder. The adjustment is made by loosening screw V.

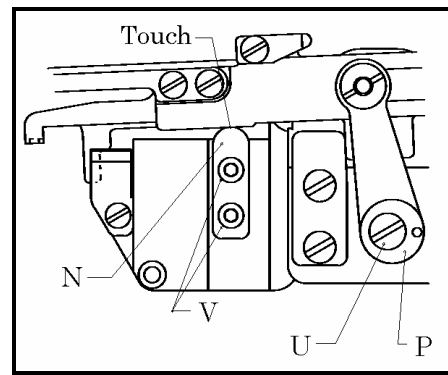
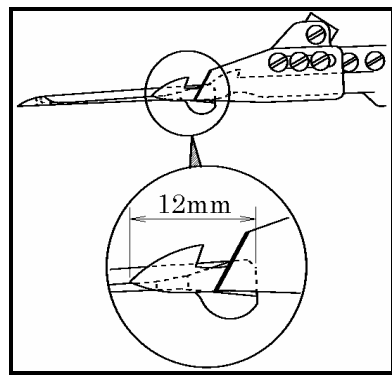

5-7 Relationship between the movable knife, needle thread and looper thread

After all the adjustments are made, check the following before threading to start the machine.

- Movable knife A should enter needle thread loops B. Cutting edge C for the looper thread should pass looper thread D.

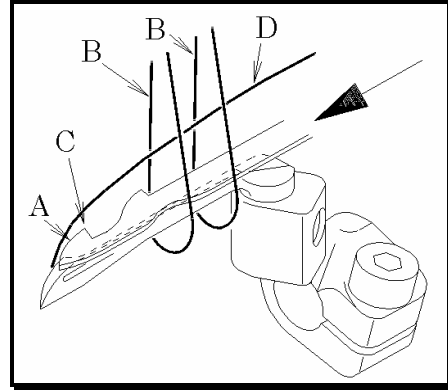

- When the movable knife is returning home, the needle threads and looper thread are pulled to the right by cutting edges E and F and cut by the stationary knife.

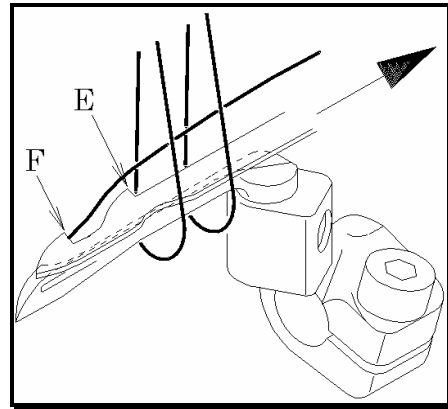

5-8 Looper thread clamp spring pressure

The looper thread clamp spring holds the looper thread after it is cut. To adjust the pressure of thread clamp spring H, turn adjusting screw G. To increase the pressure, turn it clockwise. To decrease the pressure, turn it counterclockwise. The machine is supplied with a spun thread (#60). The pressure of the thread clamp spring is factory-set at approximately 90g. Adjust the pressure for other threads.

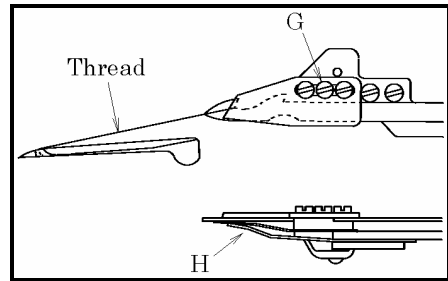

【6】 ADJUSTING THE THREAD RELEASER

6-1 Thread releaser block

With the thread trimmer air cylinder rod at the left end (the air cylinder is not operating), set the clearance between thread trimmer air cylinder bracket A and thread releaser block B at 13mm.

Then tighten screw C.

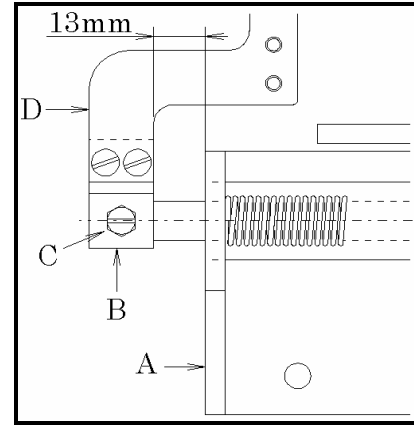

6-2 Thread releaser connection plate

Fit thread releaser connection plate D to guide screw E.

Create a clearance between plate D and thread releaser connection lever G. Adjustment is made by loosening screw H.

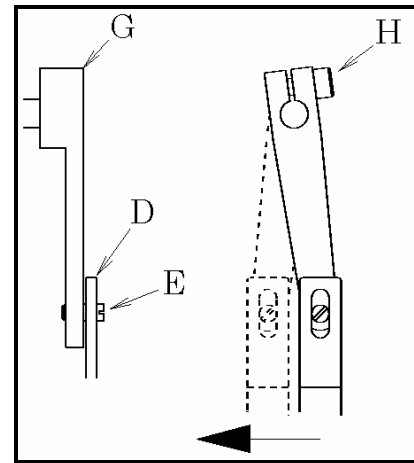

6-3 Thread releaser lever

Position thread releaser lever F so that the thread tension disk can open as fast as possible.

Then tighten screw H for thread releaser connection lever G at the rear of the arm.

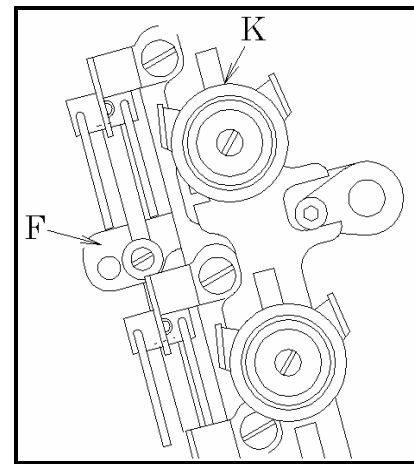

6-4 Thread releaser plate

Install thread releaser bar D to thread releaser bar connection plate F with screw G.

The top end of thread releaser bar D should protrude 27mm from the top surface of thread releaser bar guide E. There should be a clearance of 4mm between thread releaser bar adjusting collar H and thread releaser bar guide E.

6-5 Thread releaser hook

The needle thread should not protrude long from the underside of the fabric at the start of sewing.

Loosen screw I and adjust thread releaser hook J.

To decrease the amount of the thread supplied by the thread take-up, raise the thread releaser hook.

To increase the amount, lower the thread releaser hook.

If the amount is too little, the stitches cannot be formed at the start of sewing.

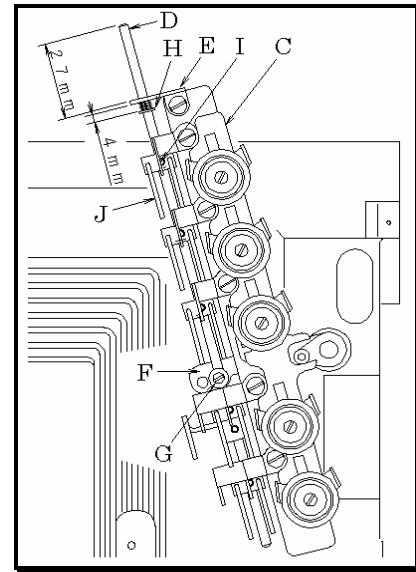

【7】 SAFETY DETECTOR

- The safety detector is included so that the machine will not start until the thread trimmer cuts the threads and returns home safely. Switch A of the detector must be pressed (ON) during sewing (with the thread trimmer completely returned home).

Adjust by loosening screws B and E and moving brackets C and D.

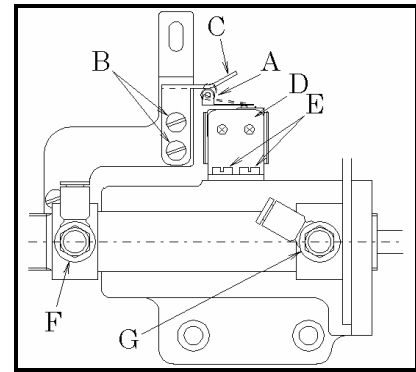

【8】 ADJUSTING THE SPEED CONTROLLER AND AIR PRESSURE

- Speed controller F controls the speed when the thread trimmer knife holder protrudes. Speed controller G controls the speed when the thread trimmer knife holder retracts. If screw F is too loosened, the holder will protrude too fast and then the position of the movable knife will be unstable, causing cutting error. If screw G is too loosened, the holder will retract too fast and then the looper thread may not be held properly (the speed controllers are factory-set).

< Note >

Set the regulator at 4~5kg/cm². To decrease the pressure, turn the adjusting knob clockwise. Too fast speed will give a shock to the knife holder. Then the threads will be cut before they are caught by the knife or the threads will not be held properly. It may cause trouble.

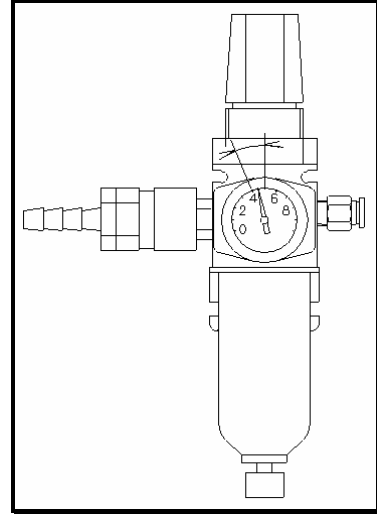

【9】 THREAD WIPER ADJUSTMENT

- Tighten screw E to position lever B horizontally. There should be a 0 to 0.3mm clearance between bracket C and stopper ring D.
- Secure shaft F with screw G. There should be 1mm clearance between lever B and secure shaft F.
- Position thread wiper K with screw H. The distance between the left end of the thread wiper and the center of the needle bar should be approximately 19mm when the thread wiper is all the way to the left and clearance between the needle center and point P of the thread wiper should be approximately 1mm.
- The distance between the left needle and thread wiper K should approximately 0.5mm with screw A.
- Position thread wiper K parallel with flat spring M with screw L.

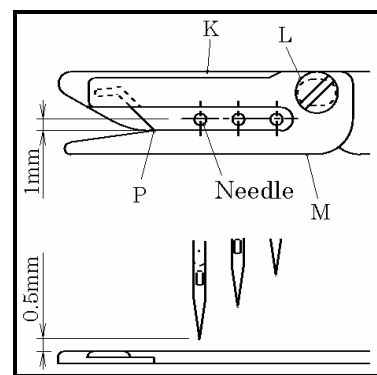
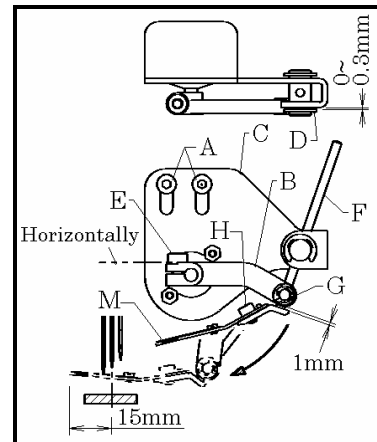

【10】 ADJUSTING THE PRESSER FOOT LIFT

- Foot lift on the machine with spreader 6mm above the top surface of the needle plate
- Foot lift on the machine without spreader 7mm above the top surface of the needle plate

To make the above adjustment, loosen screw D for crank lever C and then set the clearance between slot A on the presser bar clamp connection plate and screw B at 0.5~1mm.

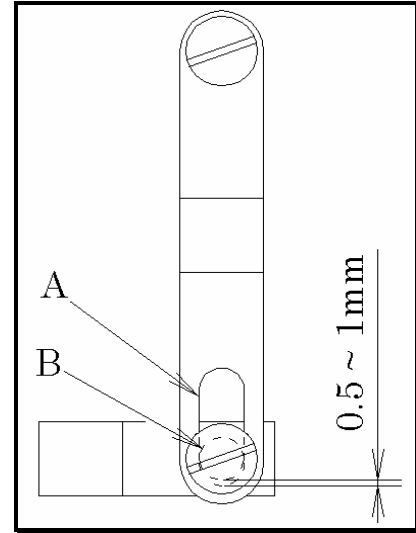
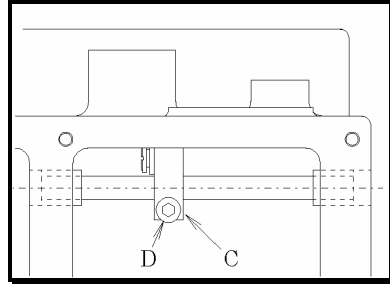

- Pneumatic presser foot lift

When the cylinder gets actuated, the presser foot should be 6mm or 7mm above the top surface of the needle plate. Position stopper E so that lever G cannot be lowered. Then secure stopper E with nut F.

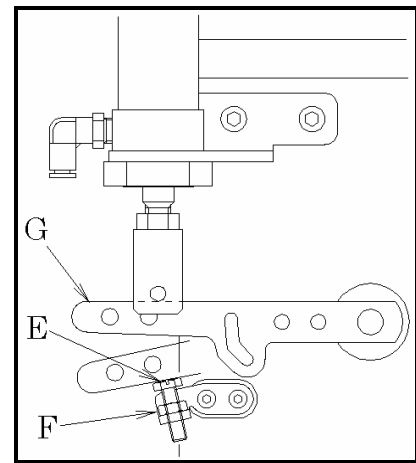

- Electric presser foot lift

When plunger H moves in direction of J, the presser foot should be 6mm or 7mm above the top surface of the needle plate. Adjust by using chain I. Position stopper E so that lever G cannot be lowered. Then secure stopper E with chain I when plunger H moves in the direction of K.

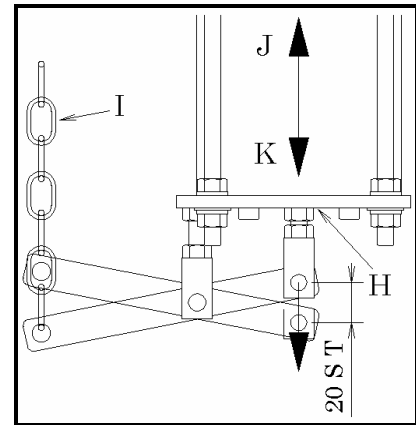

【11】 ADJUSTING THE TOP COVER THREAD TRIMMER

11-1 Relationship between the position of the movable knife and the stationary knife

- Adjust the engagement between blade for trimming thread and stationary knife to be 0.7mm when movable knife is at the extreme right. The adjustment is made by screw B.

And set the clearance between drive lever A and bracket C at approximately 1.5mm.

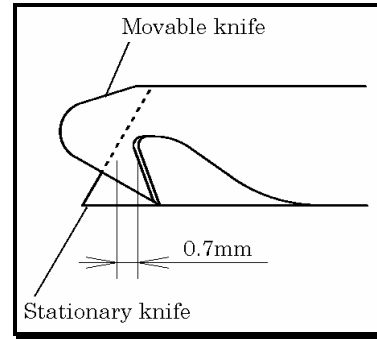

- The stroke of the movable knife should be 20mm. To adjust this stroke, loosen screws E, and set the clearance between pin F and top of the cover D at 20mm. (Refer to the right illustration.)

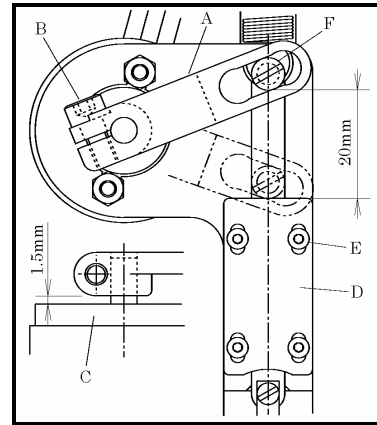

11-2 Adjustment the top cover thread clamp spring and the movable knife pressure spring

- Top cover thread clamp spring G should protrude approximately 0.8mm from end of the stationary knife. Movable knife pressure spring H should retract approximately 2.7mm from end of the stationary knife.

- Loosen screws I and adjust those springs while checking springs is parallel with the stationary knife.

- Spring G holds the top cover thread after it is cut. To adjust the pressure of the spring, turn adjusting screw J. To increase the pressure, turn it clockwise. To decrease the pressure, turn it counterclockwise.

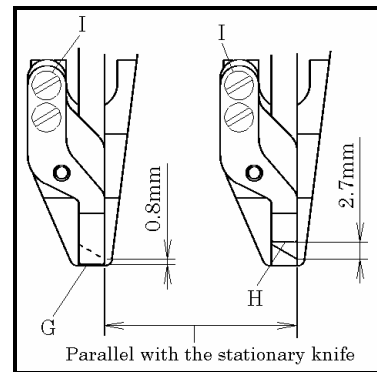

< Note >

Excessive pressure causes needle breakage.

11-3 The top cover thread trimmer installation

- Be sure that "a" of the movable knife passes over the top cover thread as shown in the right illustration. Adjustment is made by loosening screw K.

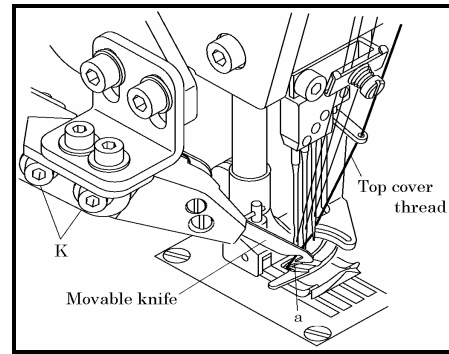

- Position the movable knife, spreader and left needle correctly. Refer to the right illustration for the relationship between the above three parts. Adjustment is made by loosening nut L.

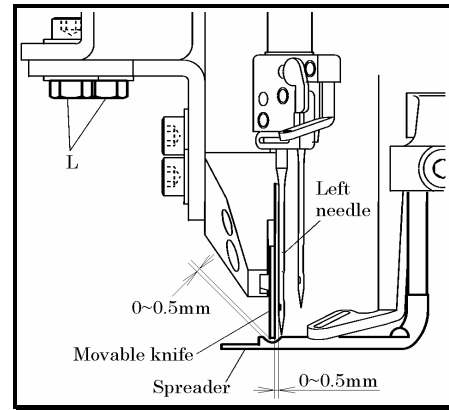

- To adjust the returning pressure of the movable knife, loosen screw P for spring bracket M and move spring bracket M up or down. To increase the pressure, move up bracket M. To decrease the pressure, move down bracket M. The pressure of spring S should be as light as possible, yet be sufficient to return the movable knife home correctly when the solenoid gets actuated.

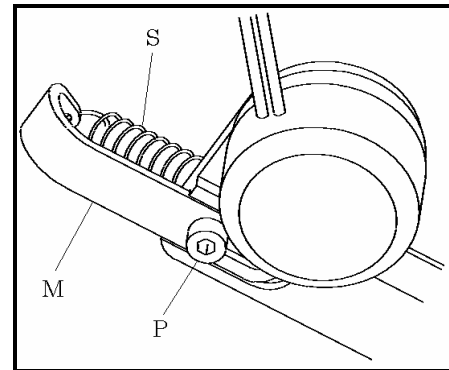

11-4 Adjusting the top cover thread releaser hook

- To decrease the amount of the thread to be supplied, move up thread releaser hook G.
- To increase the amount of the thread to be supplied, move down thread releaser hook G.
- If the amount is too small, the top cover thread cannot be held after it is cut.

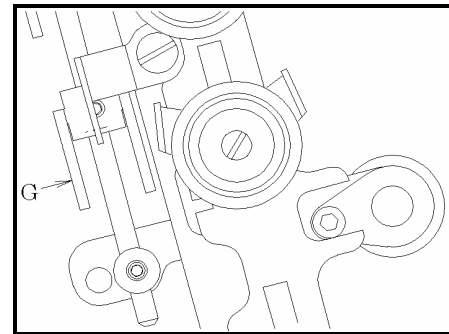

【12】 WIRING AND PIPING FOR PNEUMATIC DEVICES

- Connect air lines and cords by referring to the illustration below and the parts list.

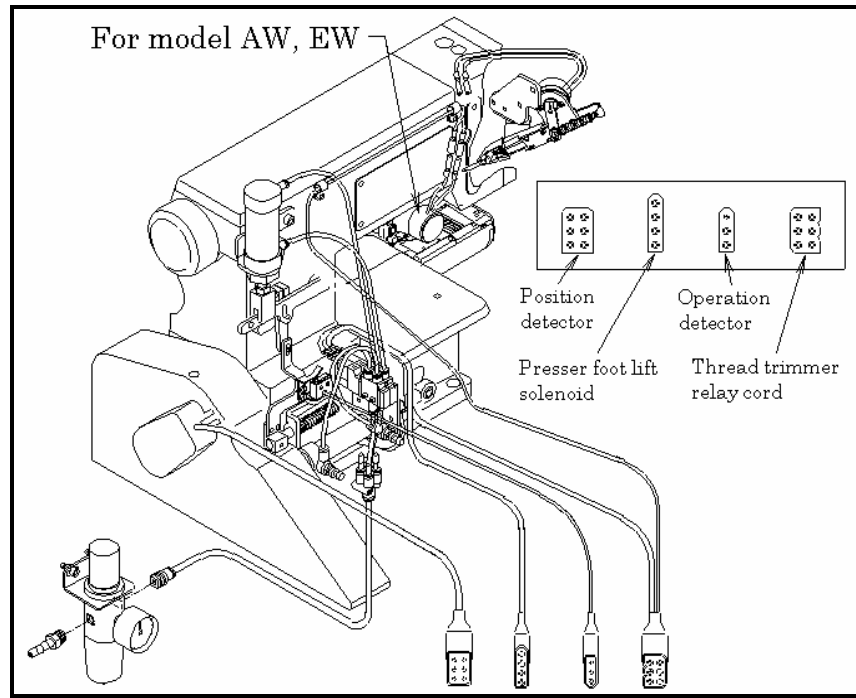

【13】 WIRING AND PIPING FOR ELECTRIC DEVICES

- Connect air lines and cords by referring to the illustration below and the parts list.

