

# INSTRUCTION N

[www.kansai.org.ua](http://www.kansai.org.ua)

# ***HDX*** ***SERIES***

Industrial Sewing Machines

*HDX1101*  
*HDX1102*

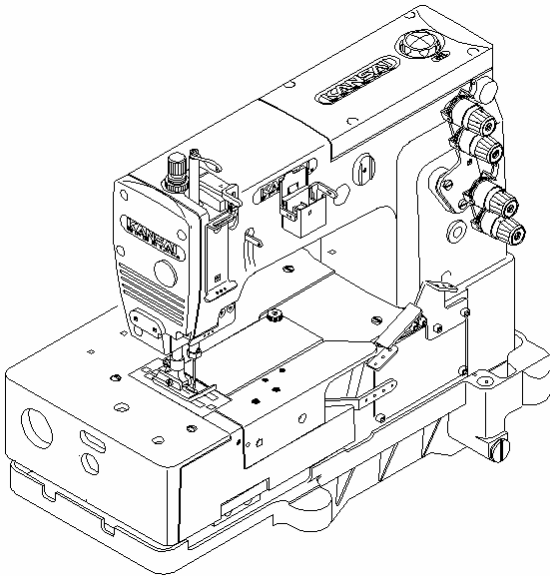

*First published : October 2003*

No. 030183

**KANSAI**  
**SPECIAL®**

## **INTRODUCTION**

*Thank you for your purchasing Kansai Special's HDX Series.*

*Read and study this instruction manual carefully before beginning any of the procedures and save it for later use.*

1. This instruction manual describes adjustments and maintenance procedures on this machine.
2. Before starting the machine, check to make sure the pulley cover, safety cover, etc. are secured.
3. Before adjusting, cleaning, threading the machine or replacing the needle, be sure to turn off the power.
4. Never start the machine with no oil in the reservoir.
5. Refer to the parts list as well as this instruction manual before performing preventive maintenance.
6. The contents described in this instruction manual are subject to change without notice.

# **CONTENTS**

<b>1. NEEDLES &amp; THREADING THE MACHINE</b>	
1-1 Needles	1
1-2 Replacing the needle	1
1-3 Threading the machine	1
<b>2. MACHINE SPEED</b>	
2-1 Machine speed & direction in which the machine pulley runs	2
2-2 Motor & belt	2
<b>3. LUBRICATION</b>	
3-1 Oil	3
3-2 Oiling	3
3-3 Replacing the oil and the filter element	3
<b>4. SEWING MACHINE INSTALLATION</b>	
4-1 Cutting the machine table	4
4-2 Installing the machine	5
<b>5. TIMING OF THE LOOPER TO THE NEEDLES</b>	
5-1 Angle and height for installing the looper	5
5-2 Looper left-to-right movement	6
5-3 Looper setting distance	6
5-4 Needle bar height	6
5-5 Needle/looper front-to-back relationship	7
<b>6. ADJUSTING THE NEEDLE GUARDS</b>	
6-1 Position of the needle guard (rear)	7
6-2 Position of the needle guard (front)	7
<b>7. ADJUSTING THE FEED DOG &amp; STITCH LENGTH</b>	
7-1 Feed dog height & tilt	8
7-2 Stitch length	8
<b>8. ADJUSTING THE PRESSER FOOT</b>	
8-1 Presser foot pressure	8
8-2 Position of the presser foot & foot lift	9
<b>9. ADJUSTING THE STITCH FORMATION</b>	
9-1 Position of the thread support	9
9-2 The position of take-up thread eyelet	10
<b>10. CLEANING THE MACHINE</b>	10

## 【1】 NEEDLES & THREADING THE MACHINE

### 1-1 Needles

Needle of Schmetz or Organ.

Select the proper needle for the fabric and thread.

< Needles and needle size >

- HDX1101·····DR2 Nm200 , #25
- HDX1102·····UY143GS Nm200 , #25

### 1-2 Replacing the needle

When replace the needle, check the needle carefully to see that the scarf is turned to the rear of the machine (see the illustration). Then install the needle correctly.

< Note >

*Before replacing the needle, be sure to turn off the machine. A clutch motor continues running for a while after the machine is turned off.*

*Therefore keep on pressing the pedal until the machine stops.*

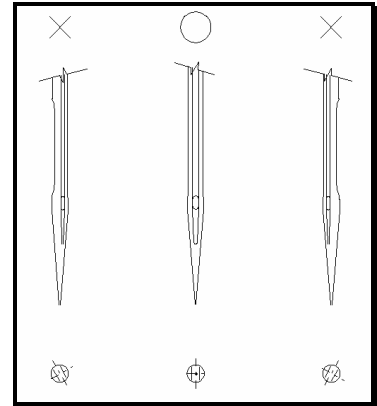

### 1-3 Threading the machine

Thread the machine correctly by referring to the illustration below.

Threading the machine incorrectly may cause skip stitching, thread breakage and/or uneven stitch formation.

< HDX1101 >

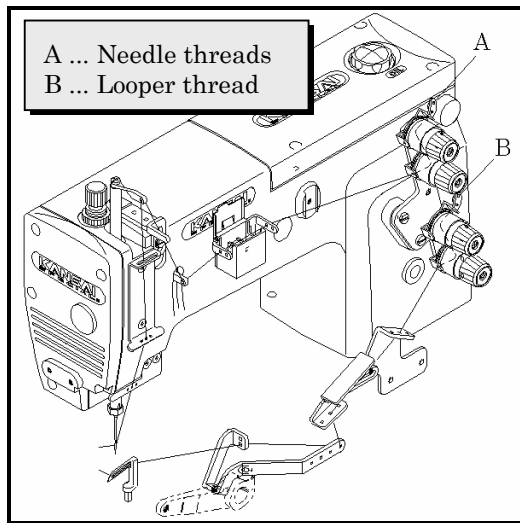

< HDX1102 >

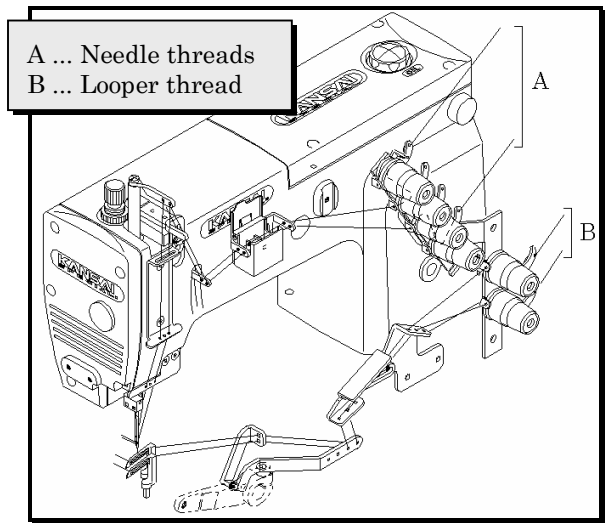

## 【2】 MACHINE SPEED

### 2-1 Machine speed & direction in which the machine pulley runs

Refer to the table below for maximum and standard speeds of the Series. To extend machine life, run the machine approximately 15-20% below the maximum speed for the first 200 hours of operation (approx. 1 month). Then run the machine at the standard speed. The machine pulley turns clockwise as seen from the end of the machine pulley.

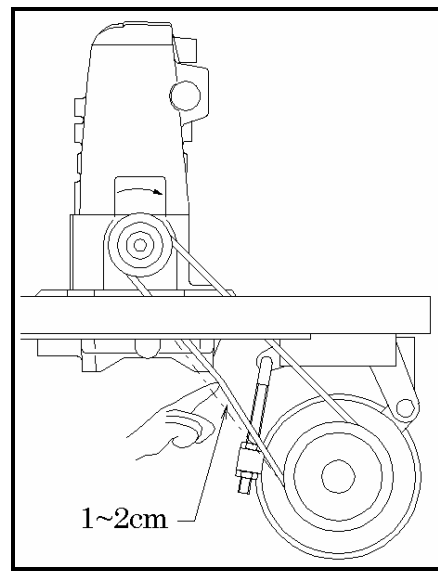

### 2-2 Motor & belt

Motor : 3-phase , 2-pole , 400W clutch motor

Belt : M type V belt

Select the proper motor pulley according to the machine speed (refer to the motor pulley outer diameter on the table below). Adjust where to position the motor by pressing the finger onto the middle of the belt so that 1~2cm deflection can be obtained (see the illustration on the right).

< Machine speed >

Type	Maximum speed	Standard speed
HDX1101	3000SPM	2500SPM
HDX1102	3000SPM	2500SPM

< Motor pulley selection table >

Motor pulley outer diameter (mm)	Machine speed (SPM)	
	50Hz	60Hz
60	2500	2950
70	2900	3450
80	3300	3900
90	3700	4400

## **【3】 LUBRICATION**

### **3-1 Oil**

Use Kansai Special's genuine oil.  
(Part No. 28-611)

### **3-2 Oiling**

- To fill the machine with oil  
Remove oil plug A from the oil hole.  
Fill the machine with oil until the oil level is at the top line (see H in the illustration) on oil gauge C.  
After the first lubrication, add oil so that the oil level will be between H and L.
- To check for proper oil flow  
After filling the machine with oil, run the machine to check the oil is splashing from oil pipe outlet B.

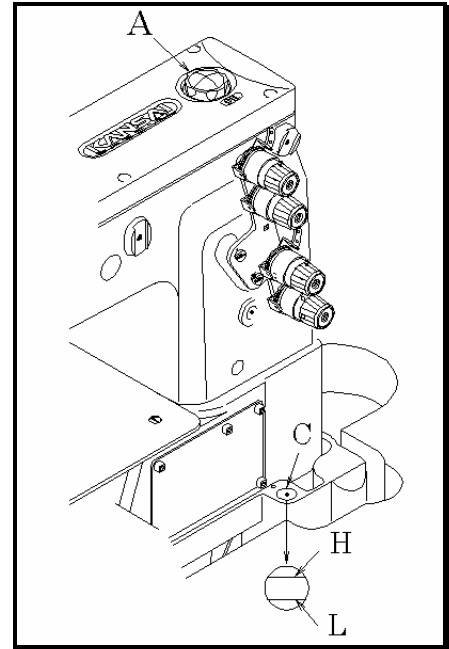

### **3-3 Replacing the oil and the filter element**

To extend machine life, be sure to replace the oil after the first 250 hours of operation.

To replace the oil, follow the procedures below.

1. Remove the V belt from the motor pulley and then remove the machine from the table.
2. Remove screw D and then drain the oil.  
Be careful not to stain V belt with the oil.
3. After draining the oil, be sure to tighten screw D.
4. Fill the machine with oil by referring to 3-2 shown above.

If filter element E is contaminated, proper oiling may not be performed. Clean the filter element every six months. If just a little or no oil flows out from the nozzle with the proper amount of oil in the machine, check the filter element. To clean the filter element, remove oil reservoir.

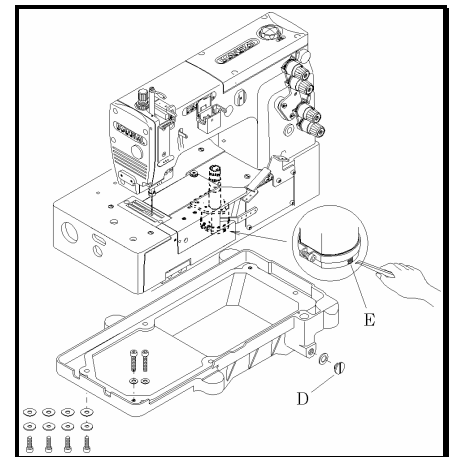





#### 4-2 Installing the machine

Install the brackets on the underside of the table board (see the illustration below).

Fit the rubber cushions onto the brackets.

Mount the machine head on the rubber cushions.

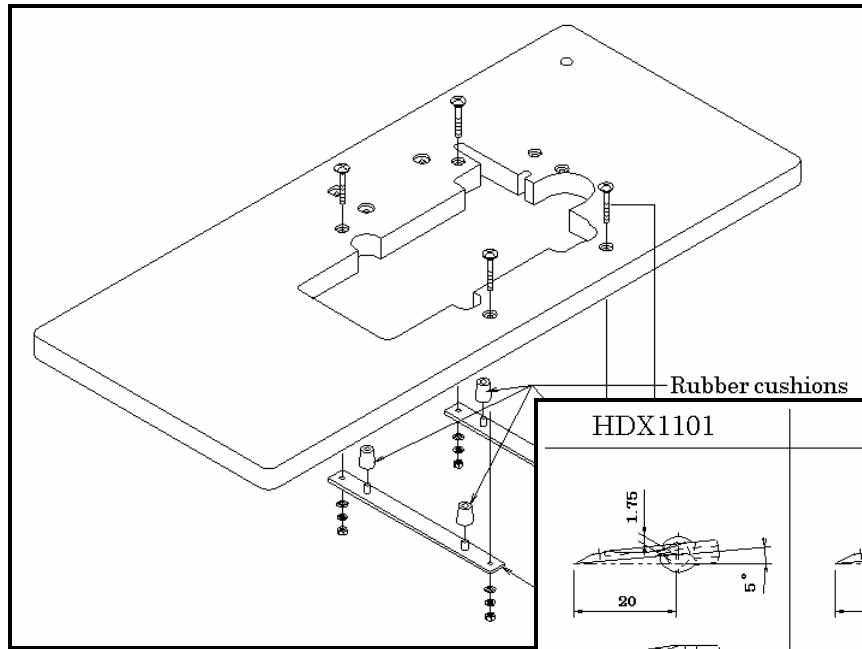

**[5]TIMING  
OF THE  
LOOPER TO  
THE  
NEEDLES**

**5-1**

#### Angle and height for installing the looper

To obtain the proper angle and height, insert the looper fully into looper holder A and then tighten screw B.

The proper angle for the looper on HDX is 5°. Distance at 20mm from the point of the looper between the bottom of the looper blade and the extension line from the point of the looper : Approximately 1.75mm.

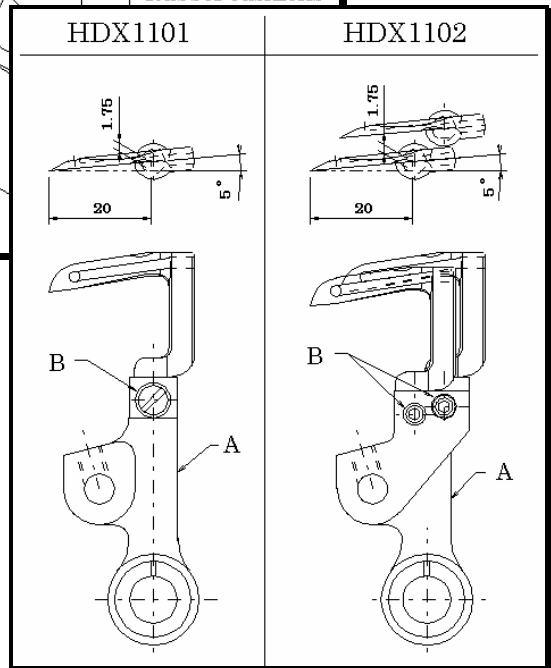

### 5-2 Looper left-to-right movement

When the point of the looper moves from the right/left to the left/right, distance A from the top of the needle's eye to the point of the looper at the left side of the needle should be equal (see the illustration on the right). To make this adjustment, remove the machine cover, loosen three screws C on looper eccentric B and then shift looper eccentric B by turning the machine pulley while holding looper eccentric B.

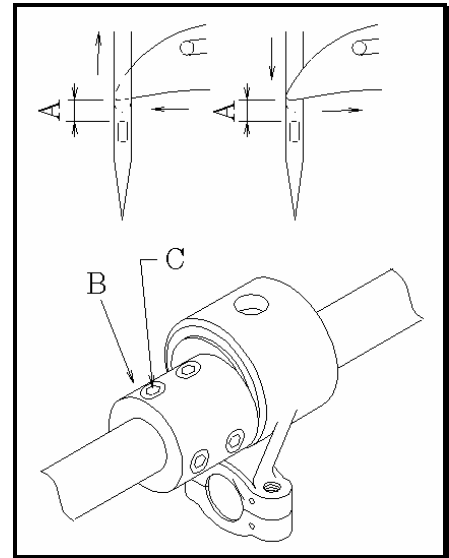

### 5-3 Looper setting distance

When the looper is at the extreme right end of its travel, adjust distance 5mm from the point of the looper to the right side of the needle. Adjustment is made by loosening screw B.

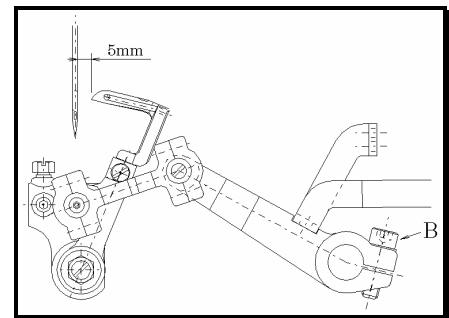

### 5-4 Needle bar height

When the point of the looper has reached the center of the needle with the machine pulley turned in the operating direction, adjust distance 2.5mm from the top of the needle's eye to the point of the looper on the back side of the needle. The adjustment is that raise needle bar up or down by remove rubber caps A and loosen the screw C.

< Note >

After the above adjustment is made, install the needle plate and then check to make sure each needle drops correctly into the center of the each needle drop hole.

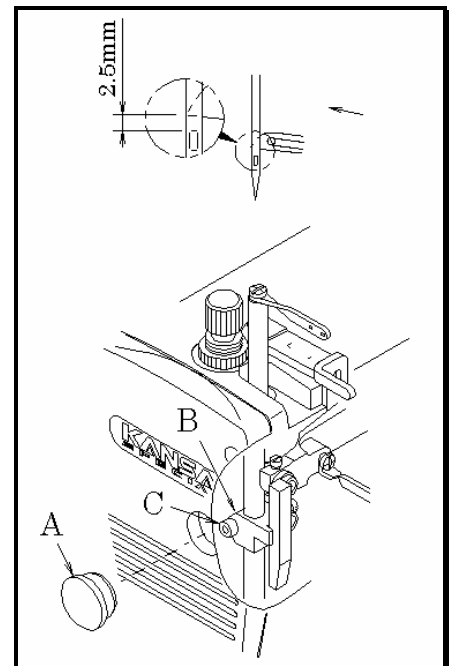

### 5-5 Needle/looper front-to-back relationship

When the looper passes on the back side of the needle, the clearance between the needle and the looper should be 0.05~0.1mm.

Adjustment is made by loosening screw A.

To increase the clearance, turn the looper avoid eccentric toward the back side of the machine.

To decrease the clearance, turn the looper avoid eccentric toward the front side of the machine.

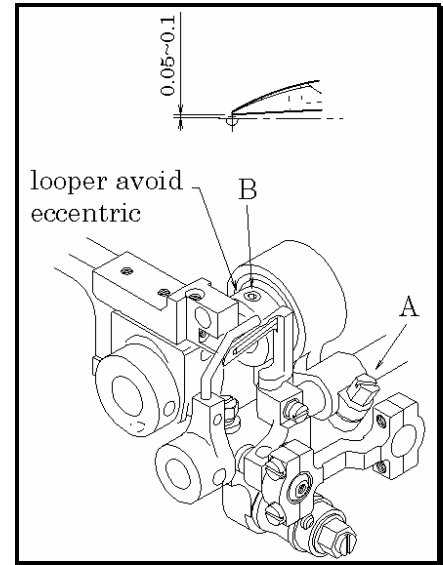

## 【6】 ADJUSTING THE NEEDLE GUARDS

### 6-1 Position of the needle guard (rear)

- The position of needle guard (rear) is when the point of looper located in behind center of needle, the clearance should be 0~0.1mm is adjusted by screw A.

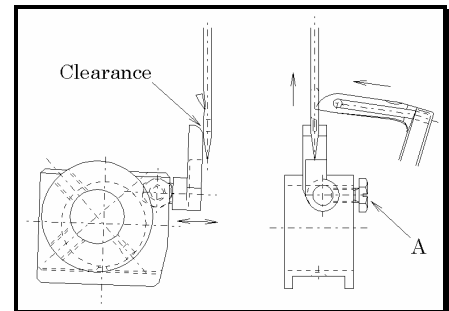

### 6-2 Position of the needle guard (front)

The height of needle guard (front) is when the point of looper located in behind center of needle, the distance should be 1.9mm from top of needle eye till bottom surface of the needle guard (front) is adjusted by screw B. The clearance between the needles and the needle guard (front) should be 0.5mm.

Adjustment is made by loosening screw C.

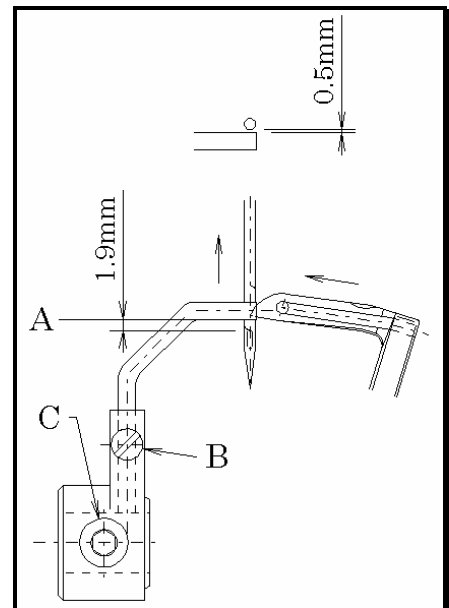

## 【7】 ADJUSTING THE FEED DOG & STITCH LENGTH

### 7-1 Feed dog height & tilt

#### ■ Height adjustment

The feed dog is at the top of its stroke, the feed dog teeth should be 2.9mm above the top surface of the needle plate. Adjustment is made by loosening screw A.

#### ■ Tilt adjustment

When the feed dog is at the top of its stroke, the feed dog teeth should be parallel with the top surface of the needle plate. Adjustment is made by loosening screw B and turning screw C.

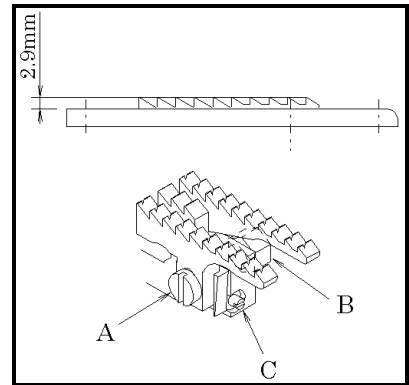

### 7-2 Stitch length

Loosen bolt A (right-hand thread) with a 9.5mm T-wrench. Then turn screw B. To increase the stitch length, turn screw B counterclockwise.

To decrease the stitch length, turn screw B clockwise.

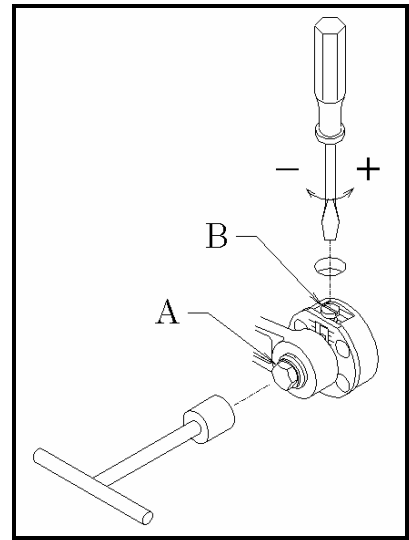

## 【8】 ADJUSTING THE PRESSER FOOT

### 8-1 Presser foot pressure

The presser foot pressure should be as light as possible, yet be sufficient to feed the fabric and produce uniform stitches. To increase the presser foot pressure, turn the adjusting knob clockwise.

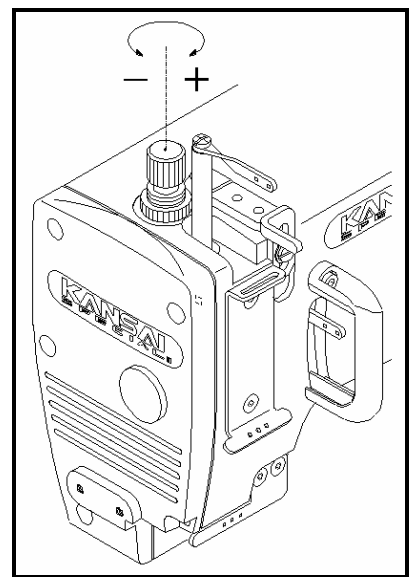



## 8-2 Position of the presser foot & foot lift

Fit the presser foot onto the presser bar so that the needle can drop correctly to the center of the presser foot needle drop hole.

- Position of the presser foot  
Loosen screw A. Adjust by moving the presser foot left or right while checking to make sure the needle drops correctly to the center of the presser foot needle drop hole.
- Foot lift  
The presser foot should be 8.5mm above the top surface of the needle plate.

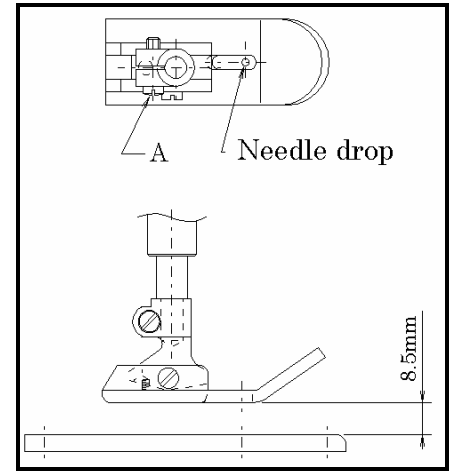

Set stopper B at the required position.

Fasten the presser foot lift lever with nut C so that the lever cannot be lowered.

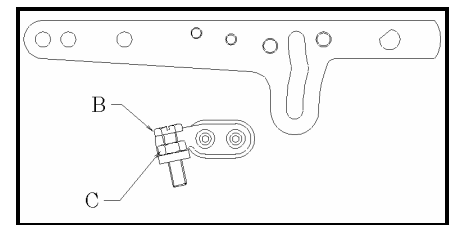

## 【9】 ADJUSTING THE STITCH FORMATION

### 9-1 Position of the thread support

When the needle bar is at the bottom of its stroke, the centers of the eyes on thread eyelet A should be level with the top surface of thread support B, and A should be parallel with B.

Height adjustment of thread support B is made by loosening screw C and moving thread support B up or down. Moving thread support B up tightens the needle thread. Moving thread support B down loosens the needle thread.

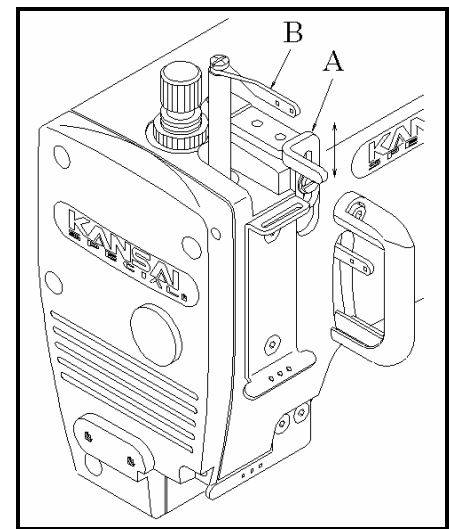

## 9-2 The position of take-up thread eyelet

Refer to the below illustration for threading by threading in direction of D to G of thread eyelet hole, the amount of under thread are decreased.

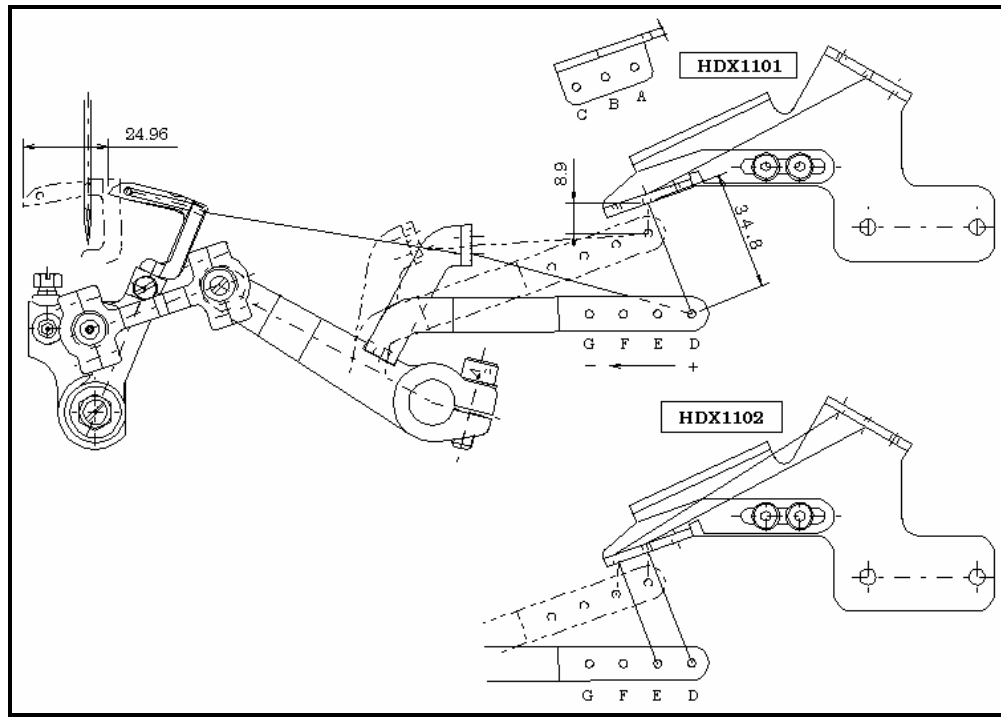

## 【10】 CLEANING THE MACHINE

At the end of each day, remove the presser foot and the needle plate and then clean the slots of the needle plate and the area around the feed dogs.

