

INSTRUCTION

FX/UTC MANUAL

www.kansai.org.ua

FX SERIES

Industrial Sewing Machines

First published : May 1997

No. 960057

KANSAI
SPECIAL®

INTRODUCTION

*Thank you for your purchasing Kansai Special's FX/UTC Series.
Read and study this instruction manual carefully before
beginning any of the procedures and save it for later use.
This instruction manual describes adjustments and maintenance
procedures for the thread trimmer.
Refer to the FX Series instruction manual for other information.*

CONTENTS

1. INSTALLING THE POSITION DETECTOR	1
2. CONNECTING RELAY CORDS AND AIR LINES	
2-1 FX4404	1
2-2 FX4406	2
2-3 FX4412	2
3. ADJUSTING THE NEEDLE STOP POSITION	3
4. ADJUSTING THE SPEED CONTROLLER AND AIR PRESSURE	3
5. HOW TO USE THE PEDAL	4
6. ADJUSTING THE THREAD TRIMMER	
6-1 Position of the movable knife	4
6-2 Position of the stationary knife	4
6-3 Adjusting the back spring	5
6-4 Adjusting the stopper	5
6-5 Disassembling and reassembling the knife assembly	6
7. ADJUSTING THE AIR WIPER	6
8. ASSEMBLING THE TENSION STAND FOR 6- TO 12-NEEDLE MACHINES	7
9. THREADING & ADJUSTING THE THREAD RELEASER	
9-1 For 4-needle machines	8
9-2 For 6- to 12-needle machines	8

1. INSTALLING THE POSITION DETECTOR

- Install the position detector by referring to the illustration on the right.

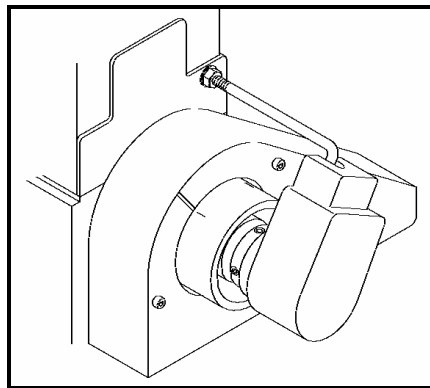

2. CONNECTING RELAY CORDS AND AIR LINES

2-1 FX4404

- Connect relay cords and air lines correctly by referring to the illustration and parts list.

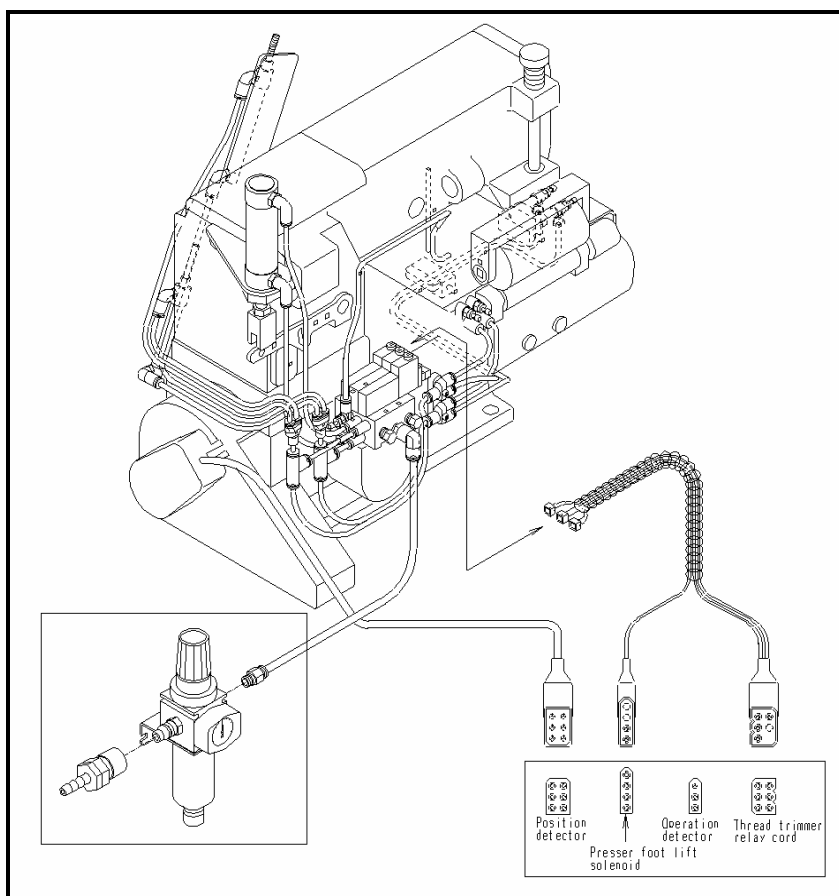

2-2 FX4406

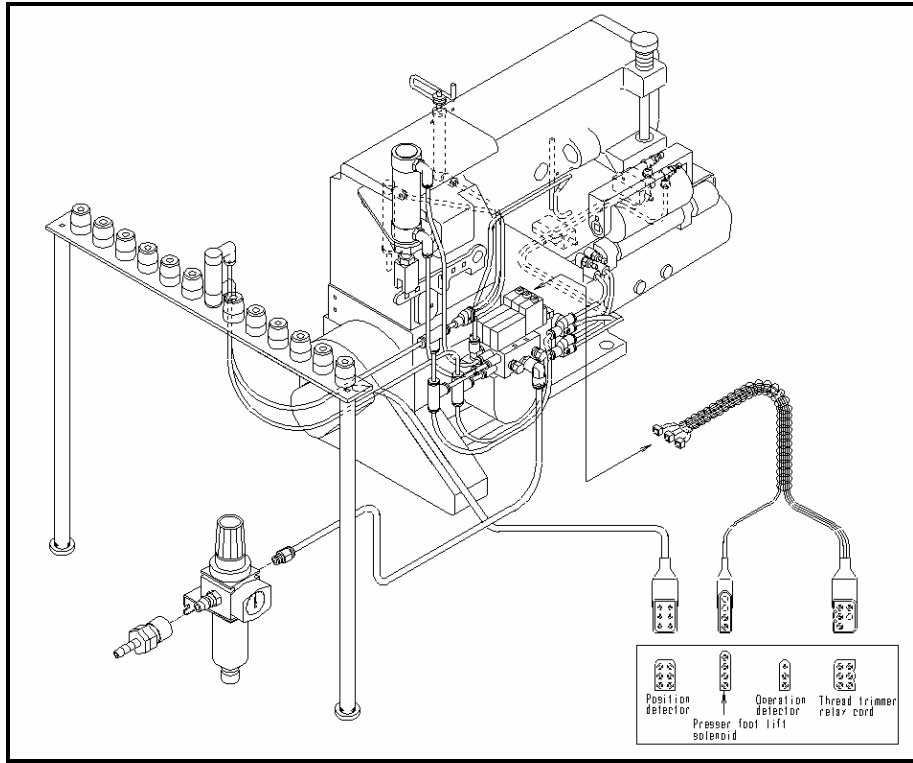

2-3 FX4412

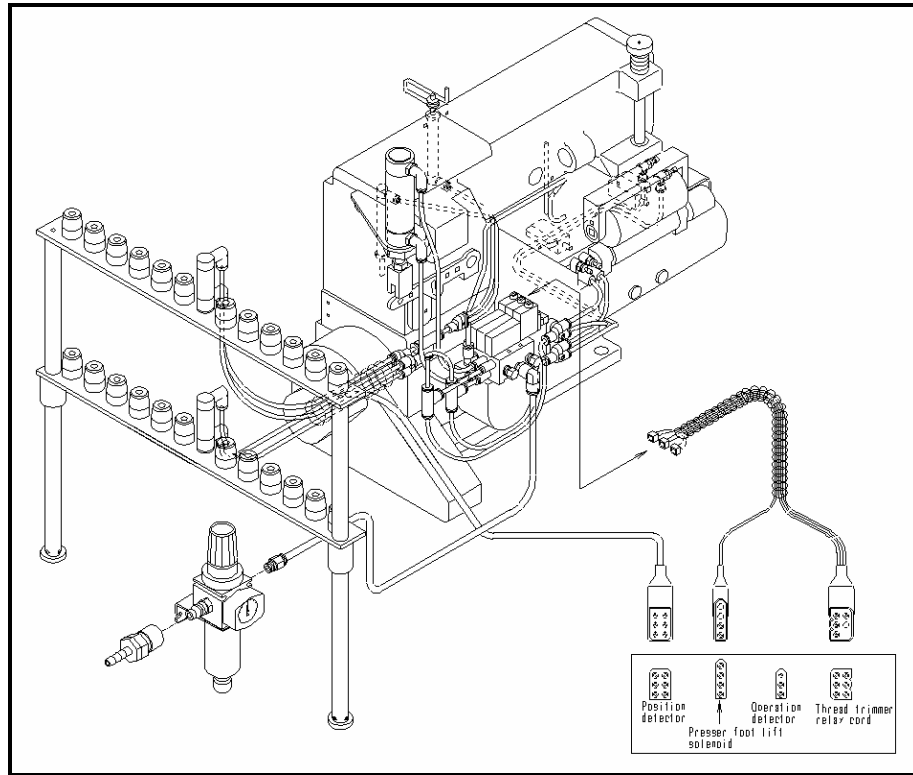

3. ADJUSTING THE NEEDLE STOP POSITION

Adjust the motor so that the needle bar stops at the top of its stroke. Then start the machine and check to see if the needle bar stops at the top of its stroke. Loosen screws A on the position detector. Align mark P on the pulley with the alignment mark on the cover. Then tighten screws A. Check to make sure again the needle bar stops at the top of its stroke.

< Note >

Do not connect the relay cord to the motor until the stop position of the needle is adjusted. Check to see if the thread trimmer knife is fully retracted. Adjust the motor so that the machine pulley turns clockwise.

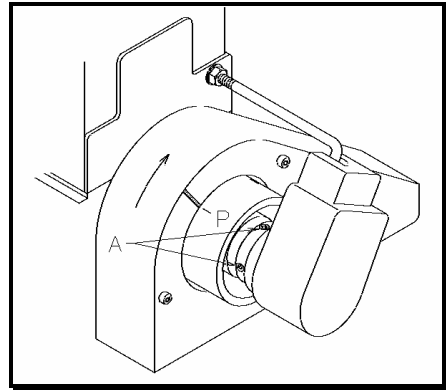

4. ADJUSTING THE SPEED CONTROLLER AND AIR PRESSURE

Speed controller A controls the speed when the thread trimming knife holder protrudes. Speed controller B controls the speed when the thread trimming knife holder retracts. If screw A is too loosened, the knife holder will protrude too fast and then the position of the knife holder will become unstable, causing cutting errors. If screw B is too loosened, the knife holder will retract too fast and then the looper thread may not be held properly (the speed controllers are factory-set).

< Note >

Set the regulator at 4 - 5kg/cm². To decrease the pressure, turn the adjusting knob clockwise. Excessive pressure will give a shock to movable parts and cause damage and trouble.

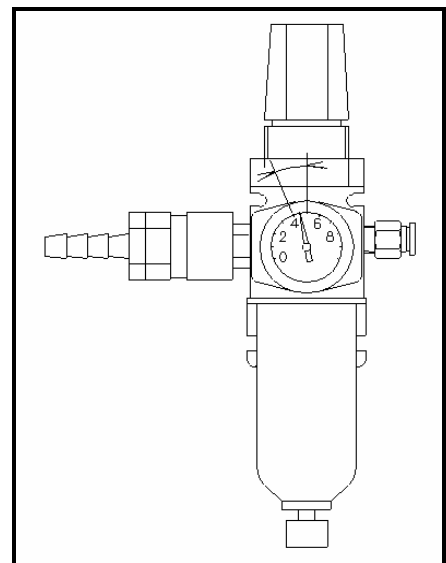
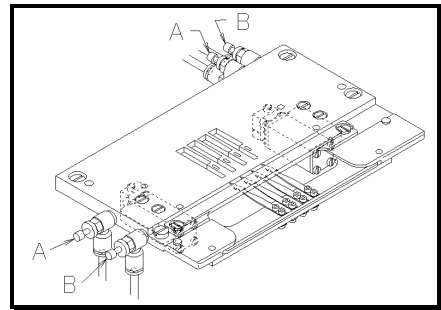

5. HOW TO USE THE PEDAL

Pressing the pedal with toe (position A) starts the machine. Releasing the pedal (position B) stops the needle at the top/bottom of its stroke (adjustable with the motor). Pressing the pedal with heel (position C) raises the needle. As soon as the needle stops at the top of its stroke by pressing the pedal with heel, the thread trimmer gets actuated (if the needle stops at the top of its stroke as adjusted, the thread trimmer gets actuated without pressing the pedal with heel). After the needle and looper threads are cut with the needle stopped at the top of its stroke, the looper thread is held by the clamp spring and the needle thread is moved up to the presser foot by the air wiper. Keep on pressing the pedal with heel to raise the presser foot. Then remove the fabric. If you want to raise the presser foot while the machine stops, press the pedal with heel (position C).

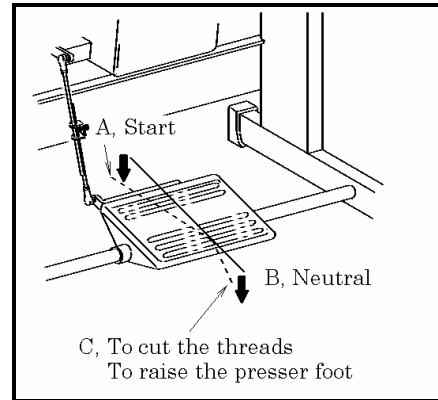

6. ADJUSTING THE TREAD TRIMMER

6-1 Position of the movable knife

Adjust movable knife A so that the bottom of movable knife base D is flush with that of movable knife A. Adjustment is made by loosening two screws C.

The point of the movable knife should be 1mm to the left of the center of the needle hole.

With the movable knife retracted, front E of the needle plate should be almost aligned with front F of the movable knife base.

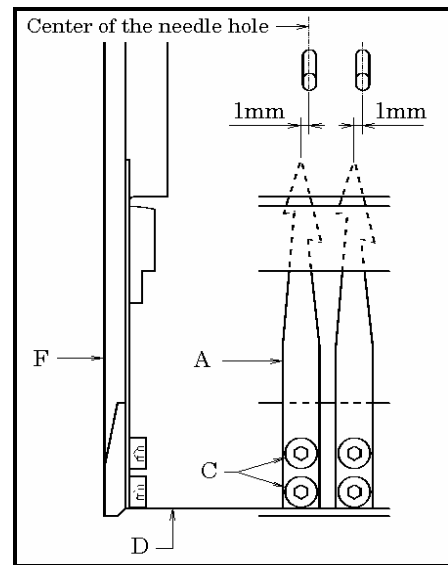

6-2 Position of the stationary knife

With the movable knife fully retracted, there should be an overlap of 0.6mm between stationary knife G and the movable knife. Adjustment is made by loosening screw H.

< Note >

If the gauge width is large, the overlap of the stationary knife and the right movable knife should be equal to that of the stationary knife and the left movable knife. To achieve this adjustment, check to see if the stationary knife is placed in a horizontal position.

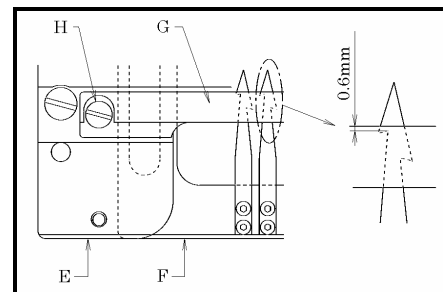

6-3 Adjusting the back spring

To cut the needle and looper threads, the movable knife moves to the stationary knife with the needle thread hooked on cutting edge A and the looper thread hooked on cutting edge B while entering the needle thread loop (see the illustration). Then the looper thread is held by the stationary knife and the back spring. Position the back spring by referring to the illustration and secure it with screws C.

< Note >

Adjust the back spring so that the back spring does not hold the needle thread after it is cut.

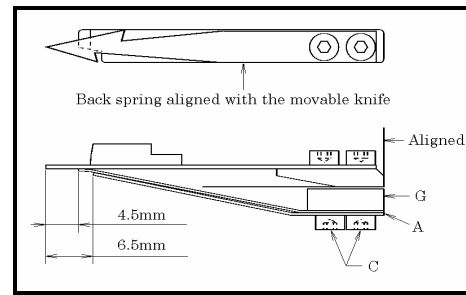
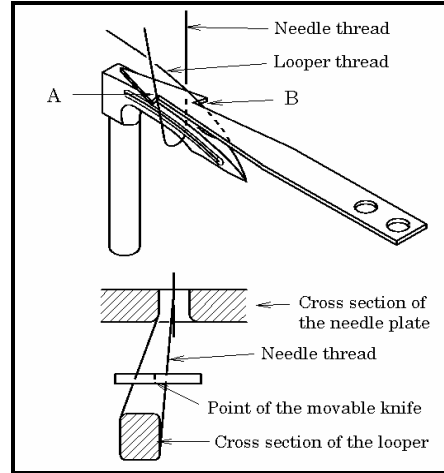

6-4 Adjusting the stopper

Stopper C adjust the position to which the movable knives protrude. With the needle bar at the top of its stroke, press the center of movable knife base B until the movable knives touch the stopper. Loosen screws D. Adjust the movable knives so that they touch the stopper when the distance from bottom surface B of the movable knife base to bottom surface A of the needle plate is approximately 18mm. Adjustment is made by loosening screws D.

< Note >

End E of the cylinder rod should tightly contact left and right stoppers C. Be sure to turn off the air when adjusting the stoppers.

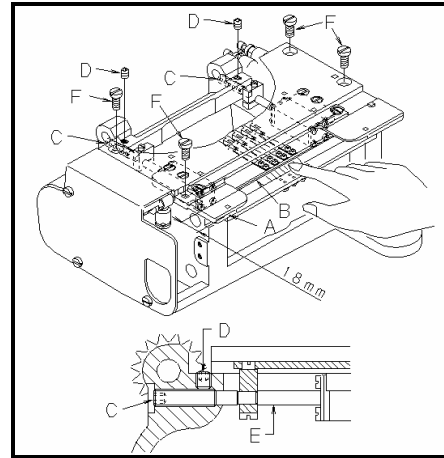

6-5 Disassembling and reassembling the knife assembly

The knife assembly is secured with four screws F. Do not loosen other screws. Perform preventive maintenance such as replacing the knife by following the procedures below.

1. Loosen screw H for front cover G. Disconnect four air lines I.
2. Loosen four screws F with the needle plate set screw.
3. Loosen screw J and remove pin K.
4. Loosen screw L. Remove presser foot lift lever L. Loosen screw M. Remove puller holder assembly N.
5. Remove the needle plate as shown in the illustration.
6. Reassemble the knife assembly by following the reverse procedures of the above after performing preventive maintenance.

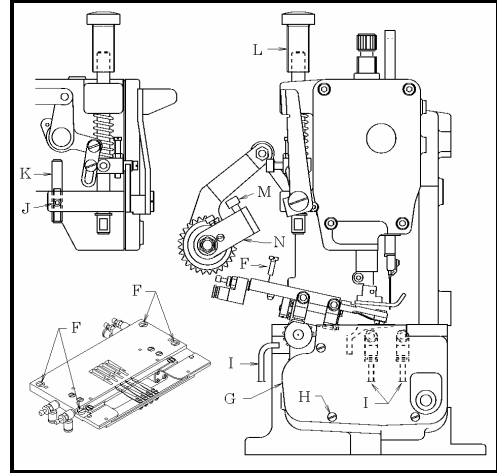

7. ADJUSTING THE AIR WIPER

The outlet of air wiper C should be positioned approximately 10mm to the right of the right needle. Adjustment is made by loosening screw A. The outlet should be 2 - 3mm below the eye of the needle. Adjustment is made by loosening screw B. The time when the air wiper is blowing is factory-set at 2 sec. Adjustment can be made by changing the settings on the motor. Read the instruction manual for the motor carefully for more information. The amount of the air should be sufficient to remove the needle thread from the fabric. Adjustment is made by turning speed control D as required (the amount of the air on FX4412P/UTC is fixed).

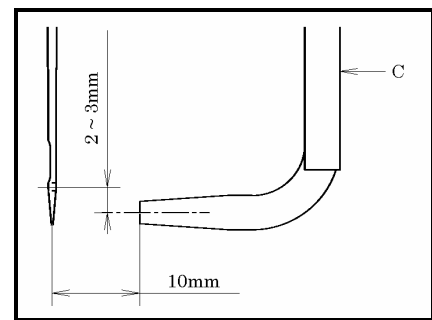
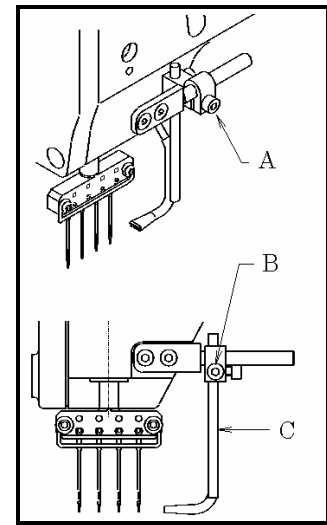
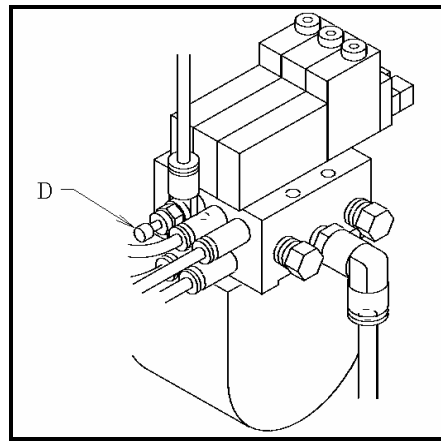

8. ASSEMBLING THE TENSION STAND FOR 6- TO 12-NEEDLE MACHINES

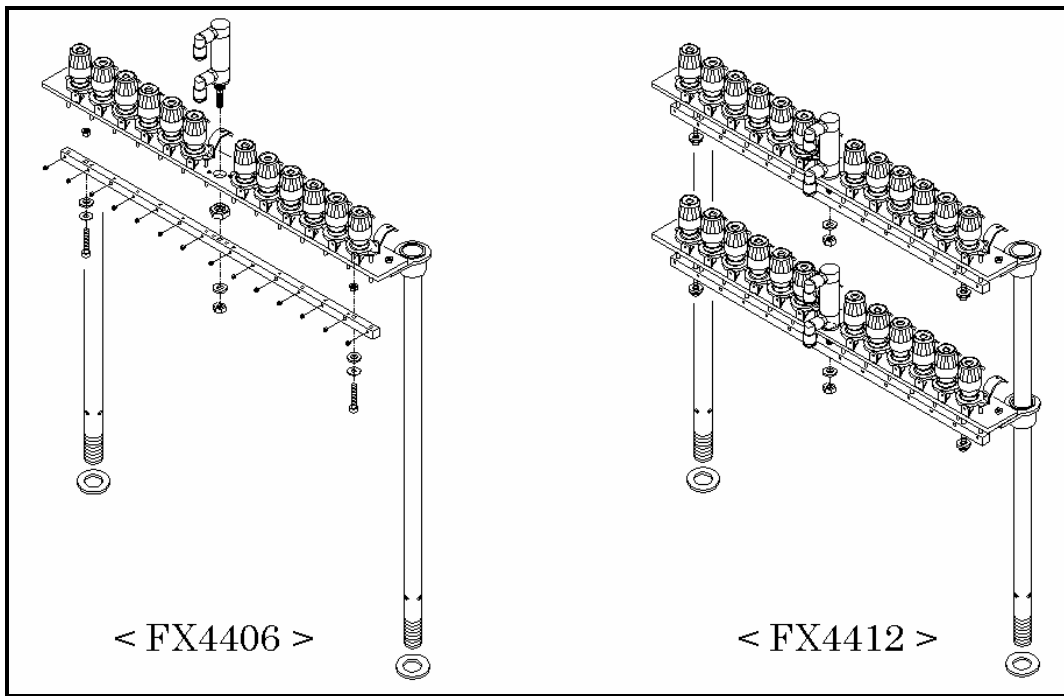

< Note >

When the air cylinder gets actuated, check to make sure tension disk A is opened by pin B.

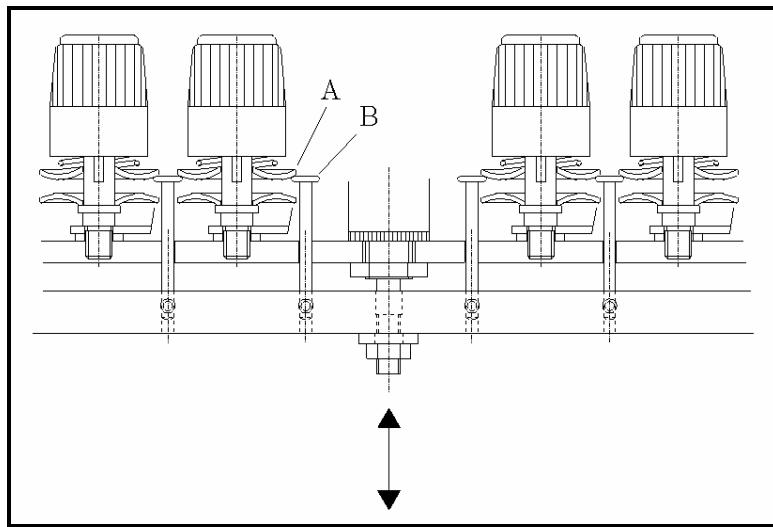

9. THREADING & ADJUSTING THE THREAD RELEASER

9-1 For 4-needle machines

Thread the machine correctly by referring to the illustration on the right. Adjust the standby position of the releaser block for the needle and looper threads according to the distance in the illustration below.

To increase the amount of the thread to be released, decrease distance A. To decrease the amount of the thread to be released, increase distance A. If stretchable threads are used, decrease distance A.

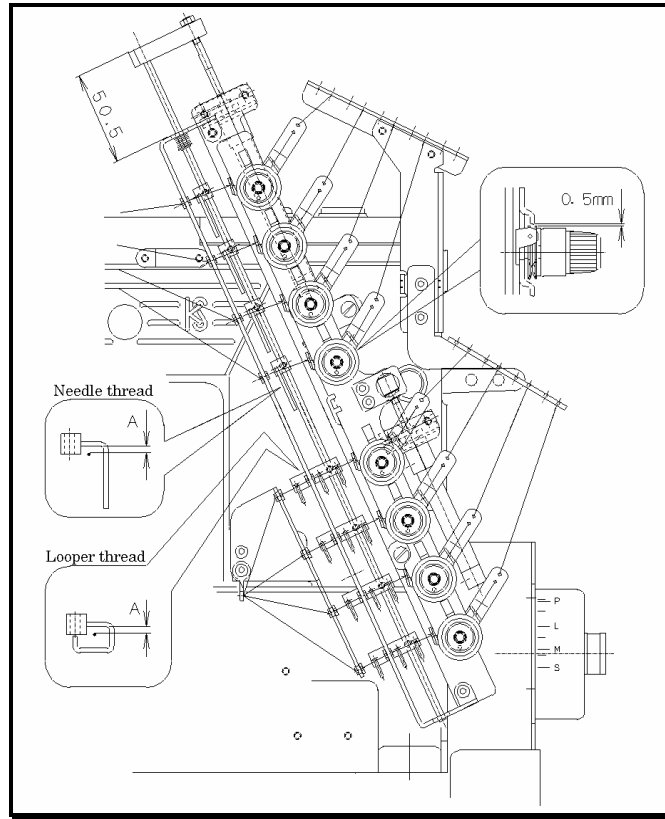

9-2 For 6- to 12-needle machines

Thread the machine correctly by referring to the illustration on the right. Install the thread eyelets for the needle and looper threads according to the distance in the illustration below.

To increase the amount of the thread to be released, decrease distance A. To decrease the amount of the thread to be released, increase distance A. If stretchable threads are used, decrease distance A.

