

INSTRUCTION

DLR SERIES

Industrial Sewing Machines

www.kansai.org.ua

First published : June 1997

No. 970066

KANSAI
SPECIAL®

INTRODUCTION

Thank you for your purchasing Kansai Special's DLR Series.

Read and study this instruction manual carefully before beginning any of the procedures and save it for later use.

1. This instruction manual describes adjustments and maintenance procedures on this machine.
2. Before starting the machine, check to make sure the pulley cover, safety cover, etc. are secured.
3. Before adjusting, cleaning, threading the machine or replacing the needle, be sure to turn off the power.
4. Never start the machine with no oil in the reservoir.
5. Refer to the parts list as well as this instruction manual before performing preventive maintenance.
6. The contents described in this instruction manual are subject to change without notice.

CONTENTS

1. SPECIFICATIONS	
1-1 Stitch type	1
1-2 Model	1
2. NEEDLES & THREADING THE MACHINE	
2-1 Needles	1
2-2 Replacing the needle	1
2-3 To thread the machine	2
3. MACHINE SPEED	
3-1 Machine speed & direction in which the machine pulley runs	4
3-2 Motor & belt	4
4. LUBRICATION	
4-1 Oil	5
4-2 To fill the machine with oil	5
4-3 Replacing the oil and the filter element	5
5. SEWING MACHINE INSTALLATION	
5-1 Cutting the machine table	6
5-2 To install the machine	7
6. TIMING OF THE LOOPER TO THE NEEDLE	
6-1 To install the looper	7
6-2 Looper left-to-right movement	8
6-3 Looper setting distance	8
6-4 Needle height	9
6-5 Needle/looper front-to-back relationship	9
6-6 Length of the looper connecting bar	10
7. ADJUSTING THE NEEDLE GUARD	
7-1 Position of the needle guard (rear)	10
7-2 Position of the needle guard (front)	10
8. ADJUSTING THE FEED DOG & STITCH LENGTH	
8-1 Feed dog height & tilt	11
8-2 Stitch length	11
9. ADJUSTING THE PRESSER FOOT	
9-1 Presser foot pressure	11
9-2 Position of the presser foot and foot lift	12
10. ADJUSTING THE REAR PULLER DEVICE	
10-1 Manual lever	12
10-2 To adjust the puller pressure	12
10-3 Adjusting the feeding amount of the rear puller	12
11. ADJUSTING THE STITCH FORMATION	
11-1 Thread tension adjustment	13
11-2 Position of the needle thread eyelet	13
11-3 Adjusting the needle thread guard	13
11-4 Adjusting the looper thread eyelets	13
11-5 Position of the looper thread take-up	14
12. ADJUSTING THE FRONT PULLER DEVICE	
12-1 To insert elastic and adjust the feeding amount of the front puller	14
13. CLEANING THE MACHINE	14

1 SPECIFICATIONS

1-1 Stitch type

JIS401 double chainstitch machines

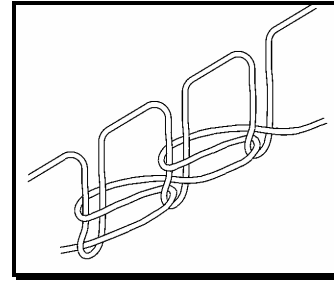

1-2 Model

Model	1501	1502□1507	1503	1504	1508
No. of needles	1	2	3	4	4
No. of threads	2	4	6	8	8
No. of loopers	1	2	3	4	4
Needle count	UY□128GAS #14~#18		TV□5 #21	UY□128GAS #14~#18	TV□5 #21
Needle space		3/16~11/2	1/4□9/32	1"□11/8	1/4-1-1/4
Needle bar stroke	31mm	34mm			

2 NEEDLES & THREADING THE MACHINE

2-1 Needles

UY□128GAS□TV□5 of Schmetz or Organ
Select the proper needle for the fabric and thread.

< Needle count comparison table >

Schmetz	Nm90	Nm95	Nm100	Nm105	Nm110	Nm120	Nm125	Nm130
Organ	# 14	# 15	# 16	# 17	# 18	# 19	# 20	# 21

2-2 Replacing the needle

When replacing the needle, check the needle carefully to see that the scarf is turned to the rear of the machine (see the illustration).

< Note >

When replacing the needle, be sure to turn off the machine. A clutch motor continues running for a while after the machine is turned off. Therefore keep on pressing the pedal until the machine stops.

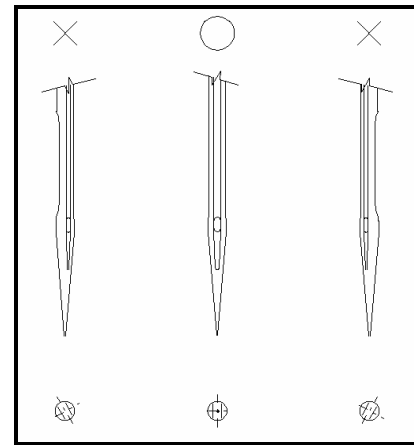

2-3 To thread the machine

Thread the machine correctly by referring to the next page.

Incorrect threading may cause skip stitching, thread breakage and/or uneven stitch formation. When threading the looper, tilt the looper holder toward the front of the machine by means of the looper drawing bar.

□ To tilt the looper toward the front

1. Bring the needle bar to the top of its stroke.
2. On 1507 and 1508, tilt looper holder B toward the front of the machine by pressing pushbutton flat spring A (see below).
3. On 1501 to 1504, tilt looper holder D to the right by pressing connecting bar C down (see below).
4. After the machine is threaded, replace the looper holder.

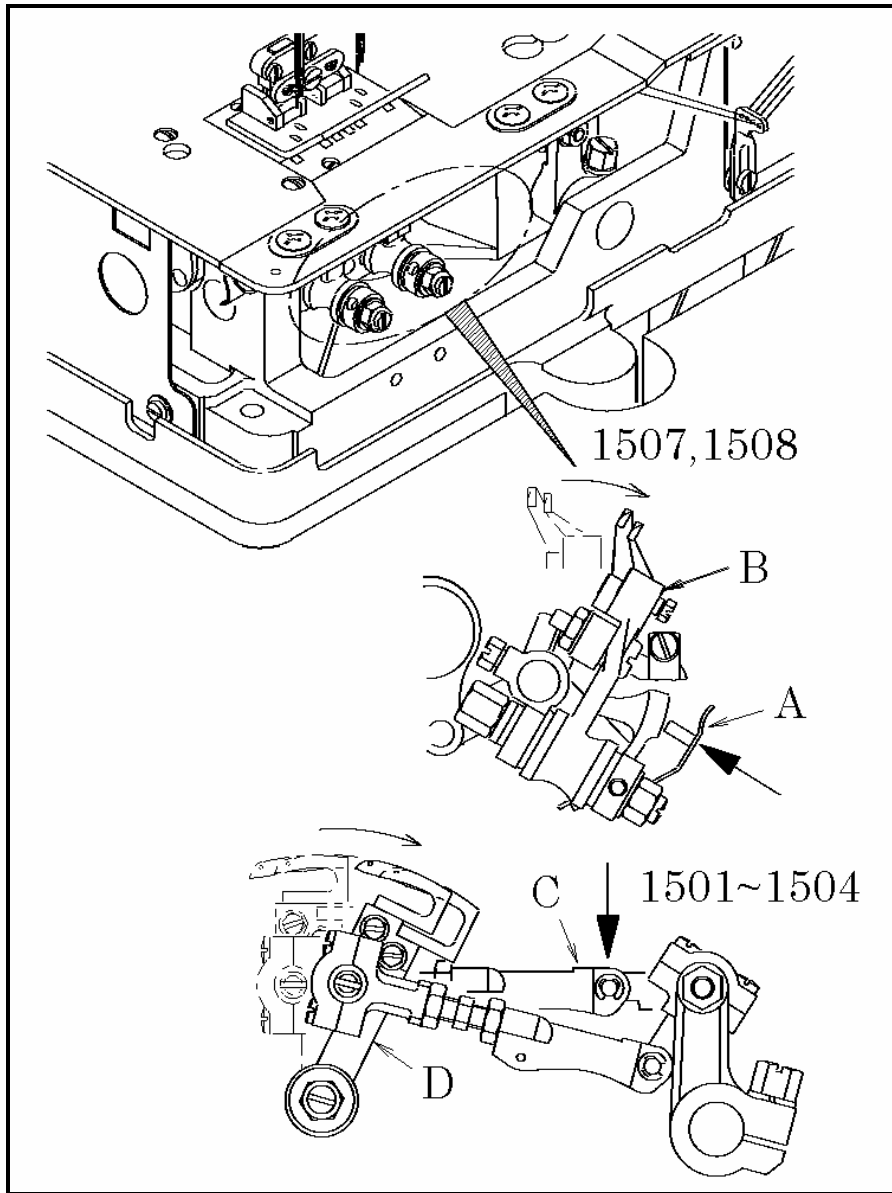

□ A□B□C□D ... Needle threads E□F□G□H ... Loper threads

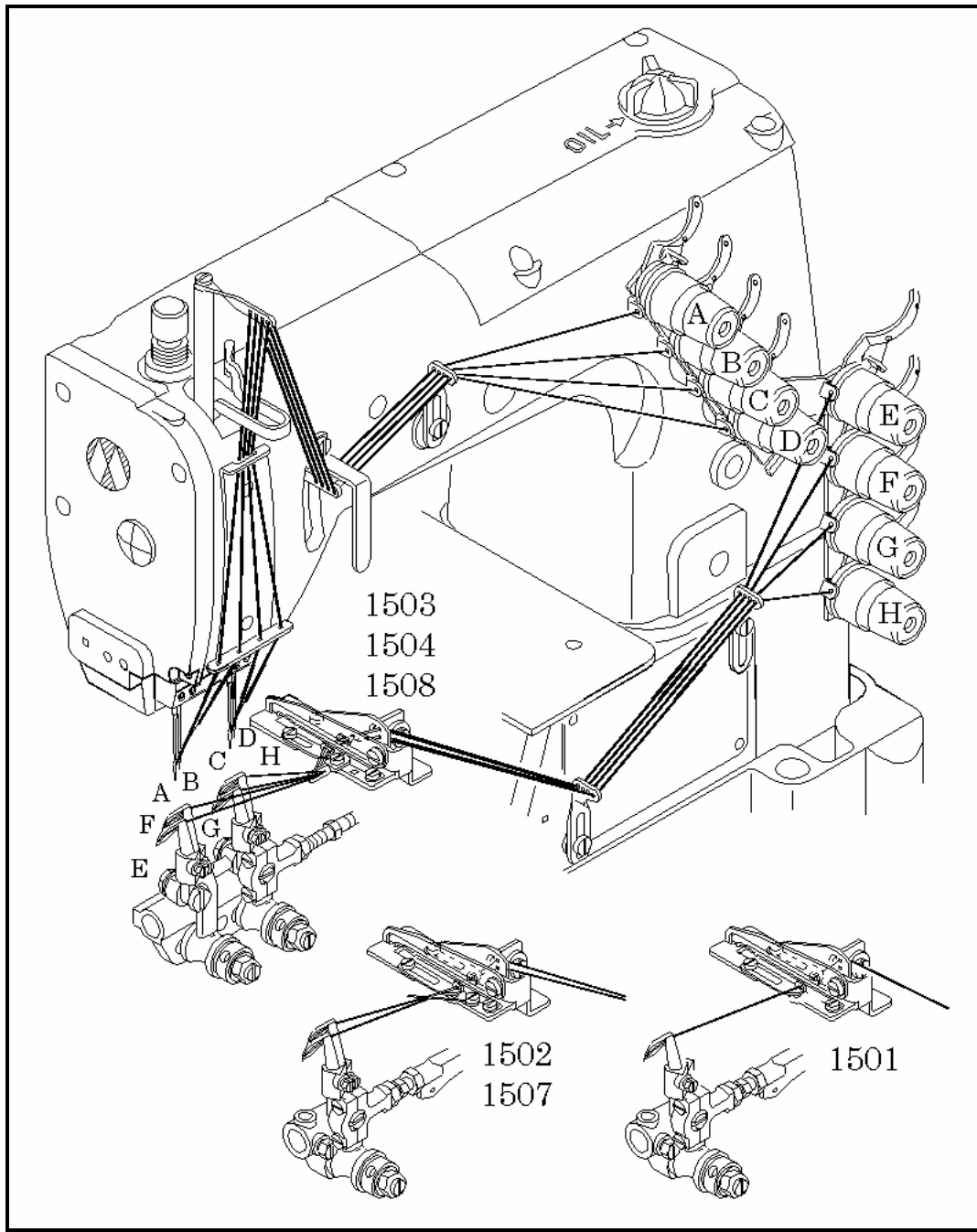

3 MACHINE SPEED

3-1 Machine speed & direction in which the machine pulley runs

Maximum speed : 4,500 rpm

Standard speed : 4,000 rpm

To extend machine life, run the machine approximately 15-20% below the maximum speed for the first 200 hours of operation (approx. 1 month).

Then run the machine at the standard speed.

The machine pulley turns counterclockwise as seen from the end of the machine pulley (see the illustration).

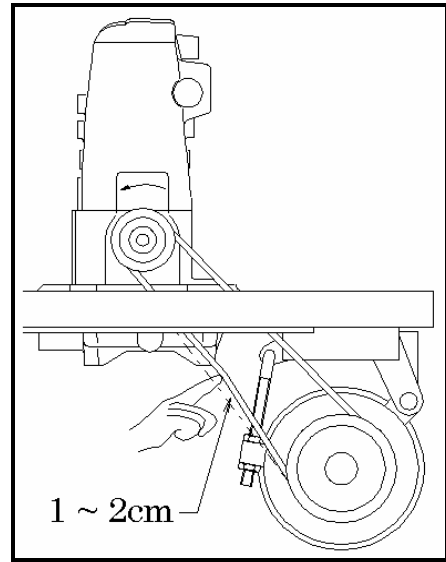

3-2 Motor & belt

Motor : 3-phase □ 2-pole □ 400W clutch motor

Belt : M type V belt

Select the proper motor pulley according to the machine speed (refer to the motor pulley outer diameter on the table below). Adjust the position of the motor by pressing the finger onto the middle of the belt so that 1~2cm deflection can be achieved (see the illustration).

< Motor pulley selection table >

Motor pulley outer diameter (mm)	Machine speed (SPM)	
	50Hz	60Hz
70	2900	3450
80	3300	3900
90	3700	4400
100	4100	(4900)
110	4500	(5400)

4 LUBRICATION

4-1 Oil

Use Kansai Special's genuine oil.
(Part No. 28-611 : 700 cc)

4-2 To fill the machine with oil

Remove oil plug A.

Fill the machine with oil until the oil level is at the top line (see H in the illustration) on oil gauge C.

After the first lubrication, add oil so that the oil level will be between H and L.

After filling the machine with oil, tighten plug A and run the machine to check the oil is splashing onto oil pot A.

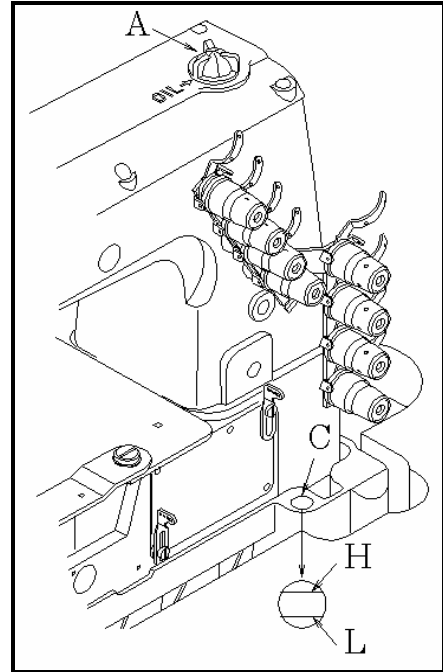

4-3 Replacing the oil and the filter element

To extend machine life, be sure to replace the oil after the first 250 hours of operation.

To replace the oil, follow the procedures below.

1. Remove the V belt from the motor pulley and then remove the machine from the table.
2. Remove screw D and then drain the oil.
Be careful not to stain V belt with the oil.
3. After draining the oil, be sure to tighten screw D.
4. Fill the machine with oil by referring to 4-2 shown above.

If filter element E is contaminated, proper oiling may not be performed. Clean the filter element every six months. If just a little or no oil flows out from the nozzle with the proper amount of oil in the machine, check the filter element. To clean the filter element, remove oil filter cap F.

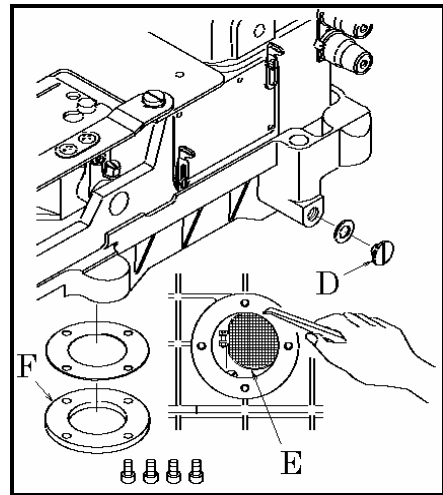

5-2 To install the machine

Install the brackets on the underside of the table board (see the illustration below).

Fit the rubber cushions onto the brackets.

Mount the machine head on the rubber cushions.

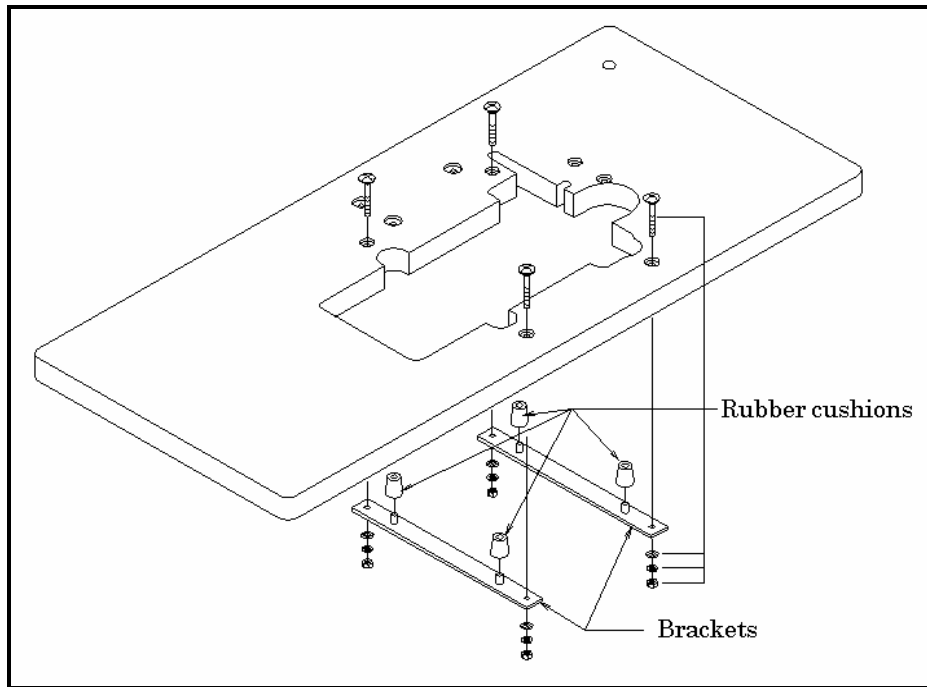

6 TIMING OF THE LOOPER TO THE NEEDLE

6-1 To install the looper

Insert the looper to the proper depth and tighten screw A.

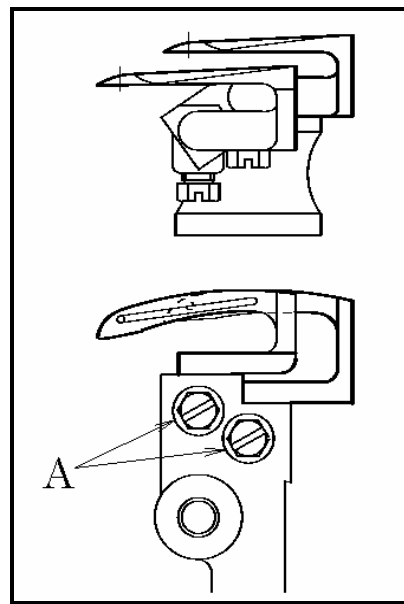

6-2 Looper left-to-right movement

When the point of the looper, moving to the left or right, has reached the center of the needle, the point of the looper should be 2mm above the top of the needle's eye. Adjustment is made by removing the cover and loosening three screws A.

After this adjustment, tighten three screws A with the same torque.

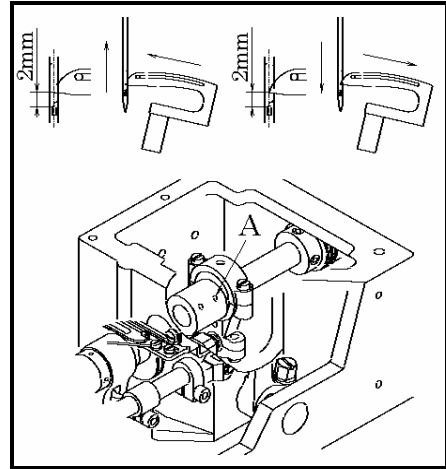

6-3 Looper setting distance

When the needle is at the bottom of its stroke and the looper is at the extreme right end of its travel, adjust distance A from the point of the looper to the center of the needle (see the table below).

Model	Looper setting Distance A
1501~1507	3.5mm
1508	3mm

- Adjustment is made by loosening screw C on lever B.

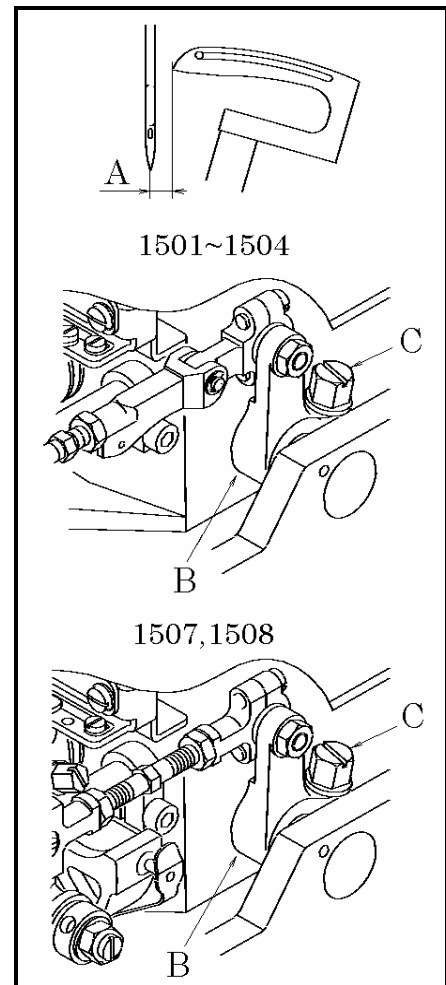

6-4 Needle height

When the point of the looper has reached the center of the back side of the needle with the machine pulley turning in the operating direction, the point of the looper should be 2mm above the top of the needle's eye (see 6-2). When the needle bar is at the top of its stroke, remove plug A on the side cover plate, loosen screw C on needle bar clamp B with a 3mm hexagonal wrench and then move the needle bar up or down as required.

< Note >

After the above adjustment is made, check to make sure each needle drops correctly into the center of each needle drop hole.

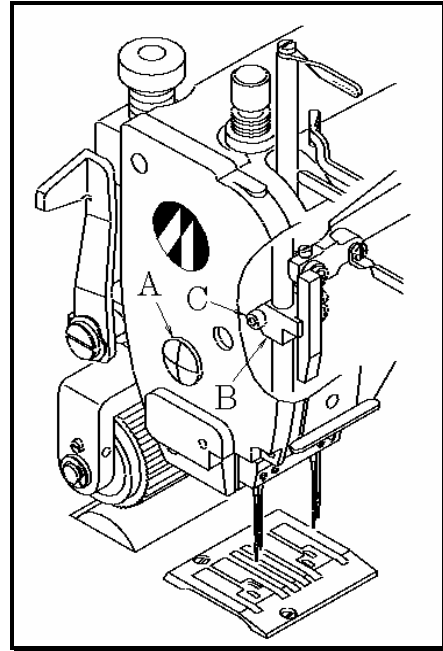

6-5 Needle/looper front-to-back relationship

When the point of the looper has reached the center of the needle, the point of the looper should be 2mm above the top of the needle's eye.

With the looper and the needle in this position, there should be a clearance of 0~0.1mm between the needle and the point of the looper.

Adjustment is made by loosening screw A on the looper avoid lever and moving looper holder B front or back.

< Note >

When moving the looper holder front or back, check to make sure the looper setting distance is not changed.

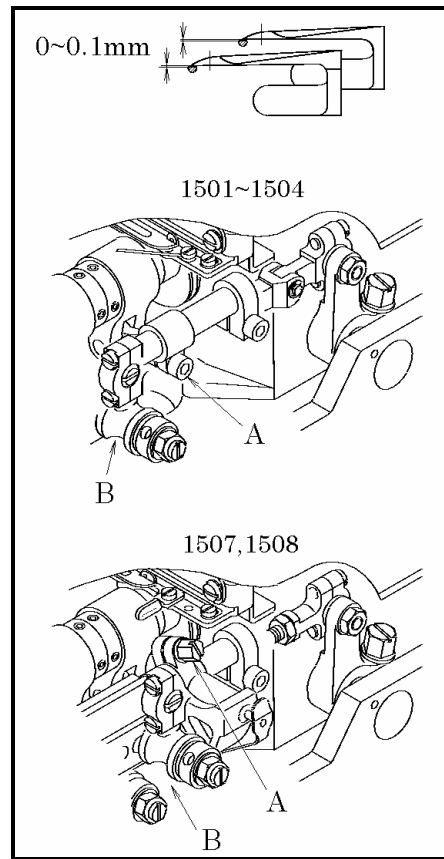

6-6 Length of the looper connecting bar

On 1501 to 1504, the distance between the centers of both connecting rods should be 100mm.

On 1507 and 1508, this distance should be 87mm.

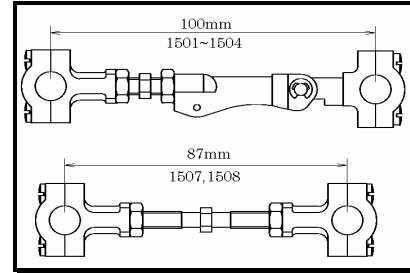

7 ADJUSTING THE NEEDLE GUARD

7-1 Position of the needle guard (rear)

When the point of the looper has reached the center of the back side of the needle from the extreme right end of its travel, align the point of the needle with bottom surface C of the needle guard (rear).

With the needle and the needle guard (rear) in this position, set clearance D between the needle and the needle guard (rear) at 0.

Adjust the needle guard (rear) front to back by loosening screw A. Adjust the needle guard (rear) up and down by loosening screw B.

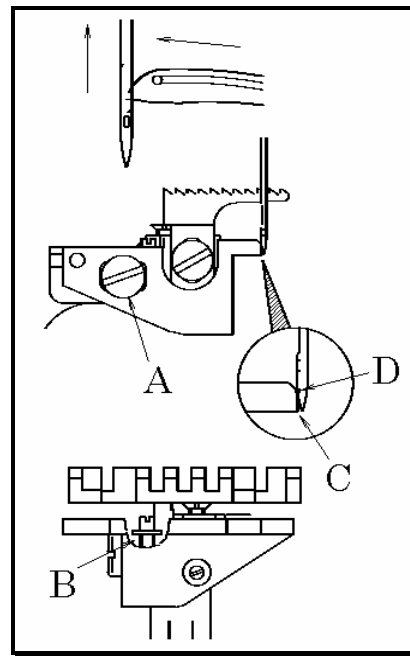

7-2 Position of the needle guard (front)

□ Adjustment for 1501PHD

When the point of the looper has reached the center of the back side of the needle from the extreme right end of its travel, set the clearance between the needle and the needle guard (front) at 0.2~0.5mm.

Adjust the needle guard (front) front to back with screw C. Turn the needle guard (front) clockwise or counterclockwise with screw B.

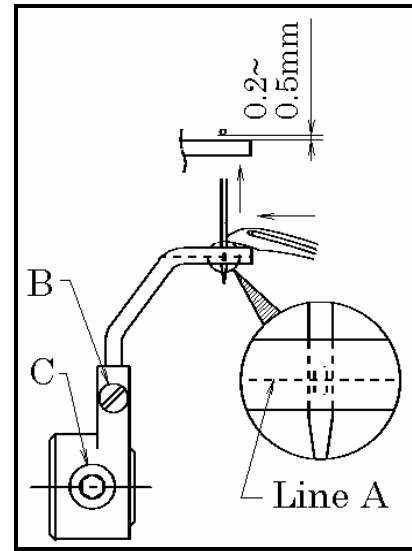

8 ADJUSTING THE FEED DOG & STITCH LENGTH

8-1 Feed dog height & tilt

When the feed dog is at the top of its stroke, the feed dog teeth should be 1.0~1.2mm above the top surface of the needle plate. Adjustment is made with screw A. The fine tilt adjustment is made by loosening nut C and turning screw B.

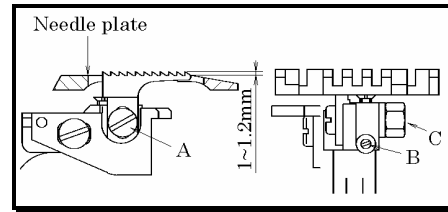

8-2 Stitch length

The stitch length can be adjusted from 2 to 5mm with no step. The following table shows the stitch length with the number of stitches within 1 inch (25.4mm) and 30mm.

Stitch length(mm)	No. of stitches	
	within 1"	within 30mm
2	13	15
3	8.5	10
5	5	6

< To change the stitch length >

1. Loosen nut A while checking the direction in which the nut is loosened.
2. Insert a screwdriver from hole C.
To decrease the stitch length, turn screw B clockwise. To increase the stitch length, turn screw B counterclockwise.
3. After this adjustment is made by turning screw B, be sure to tighten screw A.

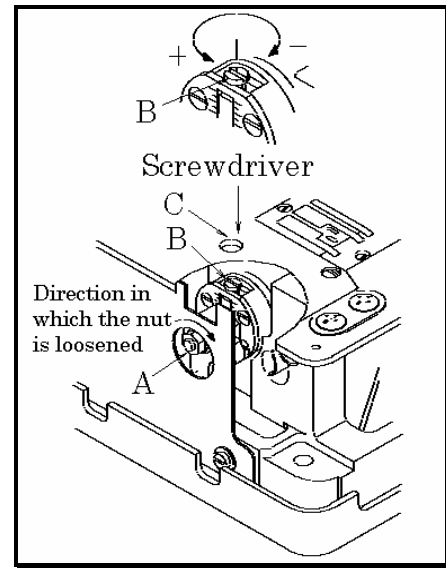

< Note >

Be sure turn off the motor when changing the stitch length.

9 ADJUSTING THE PRESSER FOOT

9-1 Presser foot pressure

The presser foot pressure should be as light as possible, yet be sufficient to feed the fabric and produce uniform stitches.

To increase the presser foot pressure, turn the adjusting knob clockwise (see the illustration).

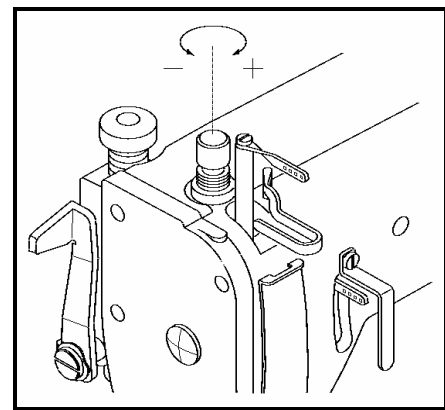

9-2 Position of the presser foot and foot lift

Fit the presser foot properly onto the presser bar.

Make sure the needle drops correctly to the center of the needle drop hole on the presser foot.

Adjustment is made by loosening screw A.

□ Foot lift

Fit collar B onto the presser foot bar bushing with the presser foot 7~10mm above the top surface of the needle plate. Then tighten screw C.

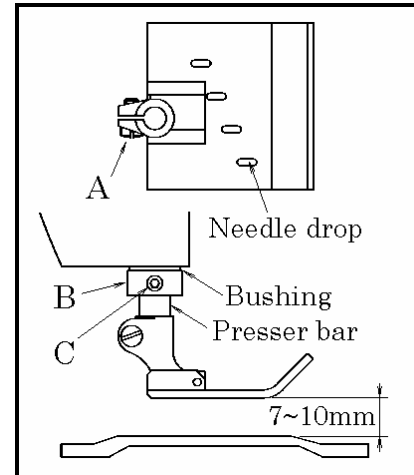

10 ADJUSTING THE REAR PULLER DEVICE

10-1 Manual lever

To position or remove the fabric, raise manual lever A.

10-2 To adjust the puller pressure

The puller pressure should be as light as possible, yet be sufficient to feed the fabric smoothly.

To increase the pressure, turn adjusting knob D clockwise. To decrease the pressure, turn adjusting knob D counterclockwise.

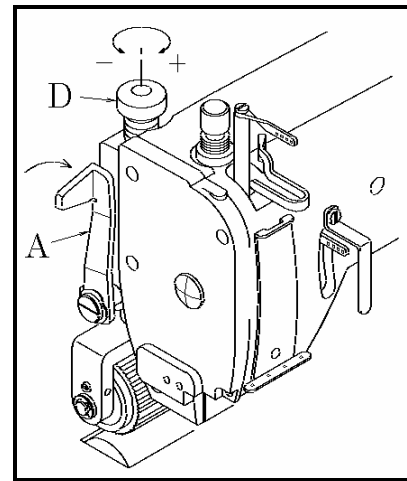

10-3 Adjusting the feeding amount of the rear puller

Adjust the feeding amount of the rear puller according to that of the feed dog.

To increase the amount, loosen nut G and move it to the left. To decrease the amount, move it to the right.

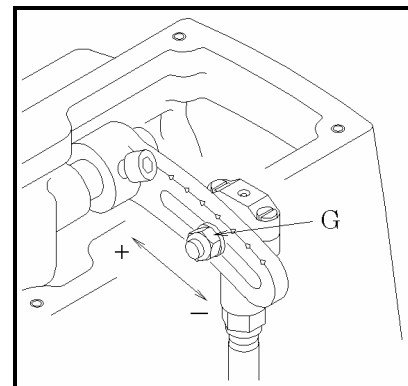

11 ADJUSTING THE STITCH FORMATION

11-1 Thread tension adjustment

Thread tension varies according to sewing conditions such as the fabric, thread and stitch length to be used. Tension on the needle thread can be adjusted with nuts A. Tension on the looper thread can be adjusted with nuts B. To increase the tension, turn the nuts clockwise.

< Note >

The tension should be as light as possible, yet be sufficient to produce uniform stitches.

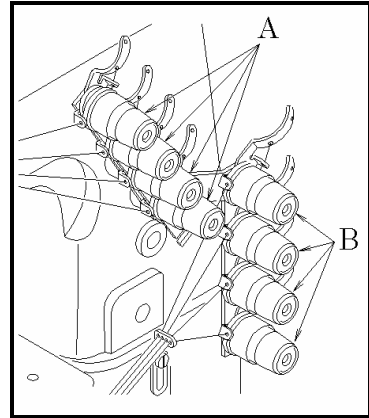

11-2 Position of the needle thread eyelet

Secure needle thread eyelet C at the bottom end of the slot.

< Note >

Adjust the needle thread eyelet according to the thread to be used. To tighten the needle thread, raise the needle thread eyelet.

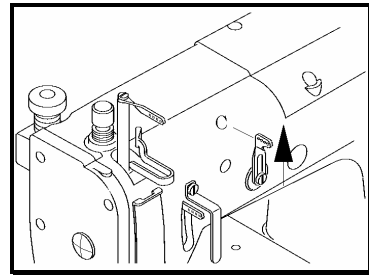

11-3 Adjusting the needle thread guard

With the needle bar at the bottom of its stroke, the top surface of needle thread guard A should be level and parallel with the centers of the eyes on needle bar eyelet B.

< Note >

Raising needle thread guard A increases the size of the needle thread loop. Lowering needle thread guard A decreases the size of the needle thread loop.

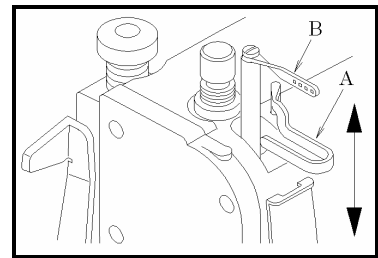

11-4 Adjusting the looper thread eyelets

Align the eyes on looper thread eyelets A with the center of the lower shaft. To increase the amount of the looper thread to be supplied, loosen screws B and move looper thread eyelets A to the rear of the machine.

To decrease the amount of the looper thread to be supplied, loosen screws B and move looper thread eyelets A to the front of the machine. On 1508P, move looper thread eyelets A fully toward the front of the machine and secure them with screws B. Adjust the looper thread eyelets according to the thread and stitch length to be used.

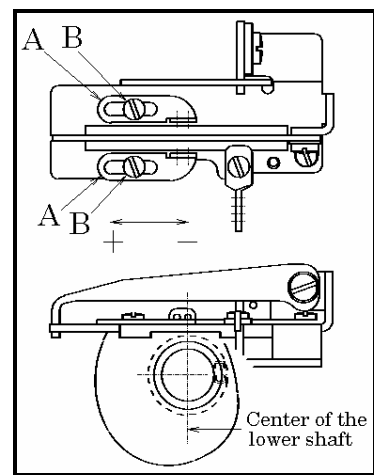

11-5 Position of the looper thread take-up

Adjust thread guide E so that the clearance between thread guide E and the top surface of the guide plate is 6~7mm. Adjustment is made by loosening screw D. When the point of the needle has reached bottom surface B of the looper blade while the looper is moving to the right from the extreme left end of its travel, the looper thread should be removed from point A on the looper thread take-up.

Adjustment is made by loosening screw C.

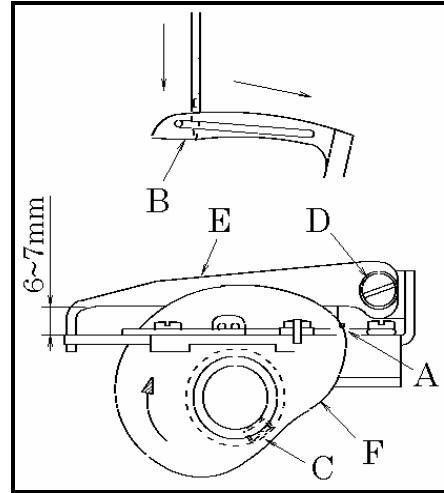

12 ADJUSTING THE FRONT PULLER DEVICE

12-1 To insert elastic and adjust the feeding amount of the front puller

Insert elastic by opening/closing small roller C with lever A (see the illustration).

Adjust the feeding amount of the front puller according to that of the feed dog.

To decrease the amount, loosen screw B and move it up. To increase the amount, loosen nut B and move it down.

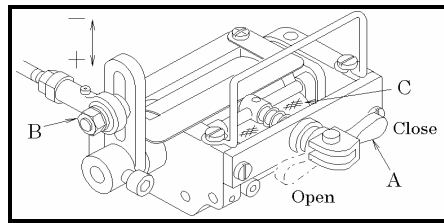

13 CLEANING THE MACHINE

At the end of each day, remove the presser foot and the needle plate and then clean the slots of the needle plate and the area around the feed dogs.

